

Standardised Water Pump

Etanorm

Installation/Operating Manual



KSb. IRAN

www.ksbiran.com

Contents

	Glossary	6
1	General.....	7
	1.1 Principles	7
	1.2 Installation of partly completed machinery.....	7
	1.3 Target group.....	7
	1.4 Other applicable documents.....	7
	1.5 Symbols	7
	1.6 Key to safety symbols/markings.....	8
2	Safety	9
	2.1 General.....	9
	2.2 Intended use	9
	2.3 Personnel qualification and training.....	9
	2.4 Consequences and risks caused by non-compliance with this manual	10
	2.5 Safety awareness	10
	2.6 Safety information for the operator/user	10
	2.7 Safety information for maintenance, inspection and installation	10
	2.8 Unauthorised modes of operation	11
	2.9 Explosion protection	11
	2.9.1 Marking	11
	2.9.2 Temperature limits.....	11
	2.9.3 Monitoring equipment.....	12
	2.9.4 Operating limits	12
3	Transport/Temporary Storage/Disposal.....	13
	3.1 Checking the condition upon delivery	13
	3.2 Transport.....	13
	3.3 Storage/preservation	14
	3.4 Return to supplier.....	14
	3.5 Disposal	15
4	Description of the Pump (Set)	16
	4.1 General description	16
	4.2 Product Information as per Regulation No. 547/2012 (for water pumps with a maximum shaft power of 150 kW) implementing "Ecodesign" Directive 2009/125/EC.....	16
	4.3 Designation.....	16
	4.4 Name plate.....	19
	4.5 Design details.....	19
	4.6 Configuration and function.....	21
	4.7 Noise characteristics	22
	4.8 Dimensions and weights	22
	4.9 Scope of supply.....	22
5	Installation at Site	23
	5.1 Safety regulations.....	23
	5.2 Checks to be carried out prior to installation.....	23
	5.3 Installing the pump set	23
	5.3.1 Installation on the foundation.....	24
	5.3.2 Installation without foundation	25
	5.4 Piping	25
	5.4.1 Connecting the piping.....	25
	5.4.2 Permissible forces and moments at the pump nozzles.....	27
	5.4.3 Vacuum balance line.....	29
	5.4.4 Auxiliary connections.....	30
	5.5 Enclosure/insulation	31
	5.6 Checking the coupling alignment	31

5.7	Aligning the pump and motor	32
5.7.1	Motors with adjusting screw	33
5.7.2	Motors without adjusting screw	33
5.8	Electrical connection	34
5.8.1	Setting the time relay	35
5.8.2	Earthing	35
5.8.3	Connecting the motor	35
5.9	Checking the direction of rotation.....	36
6	Commissioning/Start-up/Shutdown	37
6.1	Commissioning/Start-up	37
6.1.1	Prerequisites for commissioning/start-up	37
6.1.2	Filling in the lubricants	37
6.1.3	Priming and venting the pump.....	38
6.1.4	Final check	39
6.1.5	Start-up.....	40
6.1.6	Checking the shaft seal.....	41
6.1.7	Shutdown	42
6.2	Operating limits.....	42
6.2.1	Ambient temperature.....	43
6.2.2	Frequency of starts.....	43
6.2.3	Fluid handled	44
6.3	Shutdown/storage/preservation	44
6.3.1	Measures to be taken for shutdown	44
6.4	Returning to service	45
7	Servicing/Maintenance	46
7.1	Safety regulations.....	46
7.2	Servicing/Inspection.....	47
7.2.1	Supervision of operation	47
7.2.2	Inspection work.....	49
7.2.3	Lubrication and lubricant change of rolling element bearings	50
7.3	Drainage/cleaning	53
7.4	Dismantling the pump set.....	53
7.4.1	General information/Safety regulations.....	53
7.4.2	Preparing the pump set.....	54
7.4.3	Removing the motor.....	54
7.4.4	Removing the back pull-out unit	54
7.4.5	Removing the impeller	55
7.4.6	Removing the shaft seal	55
7.4.7	Dismantling the bearings	56
7.5	Reassembling the pump set.....	57
7.5.1	General information/Safety regulations.....	57
7.5.2	Fitting the bearings	57
7.5.3	Fitting the shaft seal	59
7.5.4	Fitting the impeller.....	62
7.5.5	Installing the back pull-out unit	62
7.5.6	Mounting the motor	62
7.6	Tightening torques.....	63
7.6.1	Tightening torque pump.....	63
7.6.2	Tightening torques for the pump set	64
7.7	Spare parts stock.....	64
7.7.1	Ordering spare parts.....	64
7.7.2	Recommended spare parts stock for 2 years' operation to DIN 24296	65
8	Trouble-shooting.....	66
9	Related Documents	68
9.1	General Assembly Drawings	68
9.1.1	Standardised mechanical seal and bolted casing cover.....	68
9.1.2	Standardised mechanical seal and clamped casing cover	70

9.1.3	Gland packing and bolted casing cover	72
9.1.4	Gland packing and clamped casing cover	74
9.1.5	Reinforced bearings.....	75
9.1.6	Oil lubrication with constant level oiler	76
10	EU Declaration of Conformity	77
11	Certificate of Decontamination.....	78
	Index	79

Glossary

ACS

French drinking water regulations (ACS = Attestation de Conformité Sanitaire)

Back pull-out design

The complete back pull-out unit can be pulled out without having to remove the pump casing from the piping.

Back pull-out unit

Pump without pump casing; partly completed machinery

Certificate of decontamination

A certificate of decontamination is enclosed by the customer when returning the product to the manufacturer to certify that the product has been properly drained to eliminate any environmental and health hazards arising from components in contact with the fluid handled.

Discharge line

The pipeline which is connected to the discharge nozzle

FM

Certification by FM Global (FM = Factory Mutual) regarding property insurance in industry and risk management; FM Approved products

Hydraulic system

The part of the pump in which the kinetic energy is converted into pressure energy

Pool of pumps

Customers/operators' pumps which are purchased and stored regardless of their later use.

Pump

Machine without drive, additional components or accessories

Pump set

Complete pump set consisting of pump, drive, additional components and accessories

Suction lift line/suction head line

The pipeline which is connected to the suction nozzle

UBA

German drinking water regulations to German Environment Agency

VdS

Certification for fire protection and safety by VdS

WRAS

Approved by all water suppliers in the UK (WRAS = Water Regulations Advisory Scheme)

1 General

1.1 Principles

This operating manual is supplied as an integral part of the type series and variants indicated on the front cover.

The manual describes the proper and safe use of this equipment in all phases of operation.

The name plate indicates the type series and size, the main operating data, the order number and the order item number. The order number and order item number clearly identify the pump set and serve as identification for all further business processes.

In the event of damage, immediately contact your nearest KSB Service centre to maintain the right to claim under warranty.

1.2 Installation of partly completed machinery

To install partly completed machinery supplied by KSB refer to the sub-sections under Servicing/Maintenance.

1.3 Target group

This operating manual is aimed at the target group of trained and qualified specialist technical personnel. (⇒ Section 2.3, Page 9)

1.4 Other applicable documents

Table 1: Overview of other applicable documents

Document	Contents
Data sheet	Description of the technical data of the pump (set)
General arrangement drawing/ outline drawing	Description of mating and installation dimensions for the pump (set), weights
Drawing of auxiliary connections	Description of auxiliary connections
Hydraulic characteristic curve	Characteristic curves showing head, NPSH required, efficiency and power input
General assembly drawing ¹⁾	Sectional drawing of the pump
Sub-supplier product literature ¹⁾	Operating manuals and other documentation for accessories and integrated machine parts
Spare parts lists ¹⁾	Description of spare parts
Piping layout ¹⁾	Description of auxiliary piping
List of components ¹⁾	Description of all pump components
Drawing for assembly ¹⁾	Sectional drawing of the installed shaft seal

For accessories and/or integrated machinery components observe the relevant manufacturer's product literature.

1.5 Symbols

Table 2: Symbols used in this manual







Symbol	Description
✓	Conditions which need to be fulfilled before proceeding with the step-by-step instructions
▷	Safety instructions
⇒	Result of an action
⇔	Cross-references

1) If agreed upon in scope of supply

Symbol	Description
1. 2.	Step-by-step instructions
	Note Recommendations and important information on how to handle the product

1.6 Key to safety symbols/markings

Table 3: Definition of safety symbols/markings

Symbol	Description
 DANGER	DANGER This signal word indicates a high-risk hazard which, if not avoided, will result in death or serious injury.
 WARNING	WARNING This signal word indicates a medium-risk hazard which, if not avoided, could result in death or serious injury.
CAUTION	CAUTION This signal word indicates a hazard which, if not avoided, could result in damage to the machine and its functions.
	Explosion protection This symbol identifies information about avoiding explosions in potentially explosive atmospheres in accordance with EU Directive 2014/34/EU (ATEX).
	General hazard In conjunction with one of the signal words this symbol indicates a hazard which will or could result in death or serious injury.
	Electrical hazard In conjunction with one of the signal words this symbol indicates a hazard involving electrical voltage and identifies information about protection against electrical voltage.
	Machine damage In conjunction with the signal word CAUTION this symbol indicates a hazard for the machine and its functions.



2 Safety

All the information contained in this section refers to hazardous situations.

In addition to the present general safety information the action-related safety information given in the other sections must be observed.

2.1 General

This operating manual contains general installation, operating and maintenance instructions that must be observed to ensure safe operation of the system and prevent personal injury and damage to property.

The safety information in all sections of this manual must be complied with.

The operating manual must be read and understood by the responsible specialist personnel/operators prior to installation and commissioning.

The contents of this operating manual must be available to the specialist personnel at the site at all times.

Information attached directly to the product must always be complied with and kept in a perfectly legible condition at all times. This applies to, for example:

- Arrow indicating the direction of rotation
- Markings for connections
- Name plate

The operator is responsible for ensuring compliance with all local regulations not taken into account in this operating manual.

2.2 Intended use

- The pump (set) must only be operated in the fields of application and within the use limits specified in the other applicable documents.
- Only operate pumps/pump sets which are in perfect technical condition.
- Do not operate the pump (set) in partially assembled condition.
- Only use the pump to handle the fluids described in the data sheet or product literature of the pump model or variant.
- Never operate the pump without the fluid to be handled.
- Observe the minimum flow rates indicated in the data sheet or product literature (to prevent overheating, bearing damage, etc).
- Observe the minimum flow rate and maximum flow rate indicated in the data sheet or product literature (to prevent overheating, mechanical seal damage, cavitation damage, bearing damage, etc).
- Do not throttle the flow rate on the suction side of the pump (to prevent cavitation damage).
- Consult the manufacturer about any use or mode of operation not described in the data sheet or product literature.

2.3 Personnel qualification and training

All personnel involved must be fully qualified to transport, install, operate, maintain and inspect the machinery this manual refers to.

The responsibilities, competence and supervision of all personnel involved in transport, installation, operation, maintenance and inspection must be clearly defined by the operator.

Deficits in knowledge must be rectified by means of training and instruction provided by sufficiently trained specialist personnel. If required, the operator can commission the manufacturer/supplier to train the personnel.

Training on the pump (set) must always be supervised by technical specialist personnel.

2.4 Consequences and risks caused by non-compliance with this manual

- Non-compliance with these operating instructions will lead to forfeiture of warranty cover and of any and all rights to claims for damages.
- Non-compliance can, for example, have the following consequences:
 - Hazards to persons due to electrical, thermal, mechanical and chemical effects and explosions
 - Failure of important product functions
 - Failure of prescribed maintenance and servicing practices
 - Hazard to the environment due to leakage of hazardous substances

2.5 Safety awareness

In addition to the safety information contained in this manual and the intended use, the following safety regulations shall be complied with:

- Accident prevention, health regulations and safety regulations
- Explosion protection regulations
- Safety regulations for handling hazardous substances
- Applicable standards, directives and laws

2.6 Safety information for the operator/user

- Fit protective equipment (e.g. contact guards) supplied by the operator for hot, cold or moving parts, and check that the equipment functions properly.
- Do not remove any protective equipment (e.g. contact guards) during operation.
- Provide the personnel with protective equipment and make sure it is used.
- Contain leakages (e.g. at the shaft seal) of hazardous fluids handled (e.g. explosive, toxic, hot) so as to avoid any danger to persons and the environment. Adhere to all relevant laws.
- Eliminate all electrical hazards. (In this respect refer to the applicable national safety regulations and/or regulations issued by the local energy supply companies.)
- If shutting down the pump does not increase potential risk, fit an emergency-stop control device in the immediate vicinity of the pump (set) during pump set installation.

2.7 Safety information for maintenance, inspection and installation

- Modifications or alterations of the pump (set) are only permitted with the manufacturer's prior consent.
- Use only original spare parts or parts/components authorised by the manufacturer. The use of other parts/components can invalidate any liability of the manufacturer for resulting damage.
- The operator ensures that maintenance, inspection and installation is performed by authorised, qualified specialist personnel who are thoroughly familiar with the manual.
- Only carry out work on the pump (set) during standstill of the pump.
- Only perform work on the pump set when it has been disconnected from the power supply (de-energised).
- The pump (set) must have cooled down to ambient temperature.
- Pump pressure must have been released and the pump must have been drained.

- When taking the pump set out of service always adhere to the procedure described in the manual. (⇒ Section 6.1.7, Page 42) (⇒ Section 6.3, Page 44)
- Decontaminate pumps which handle fluids posing a health hazard. (⇒ Section 7.3, Page 53)
- As soon as the work has been completed, re-install and re-activate any safety-relevant devices and protective devices. Before returning the product to service, observe all instructions on commissioning. (⇒ Section 6.1, Page 37)

2.8 Unauthorised modes of operation

Never operate the pump (set) outside the limits stated in the data sheet and in this manual.

The warranty relating to the operating reliability and safety of the supplied pump (set) is only valid if the equipment is used in accordance with its intended use. (⇒ Section 2.2, Page 9)

2.9 Explosion protection



Always observe the information on explosion protection given in this section when operating the product in potentially explosive atmospheres.

Only pumps/pump sets marked as explosion-proof **and** identified as such in the data sheet may be used in potentially explosive atmospheres.

Special conditions apply to the operation of explosion-proof pump sets to EU Directive 2014/34/EU (ATEX).

Especially adhere to the sections in this manual marked with the symbol opposite and the following sections, (⇒ Section 2.9.1, Page 11) to (⇒ Section 2.9.4, Page 12)

The explosion-proof status of the pump set is only assured if the pump set is used in accordance with its intended use.

Never operate the pump set outside the limits stated in the data sheet and on the name plate.

Prevent impermissible modes of operation at all times.

2.9.1 Marking

Pump The marking on the pump refers to the pump part only.

Example of such marking:

II 2 G c TX (EN 13463-1) or EX II 2G Ex h IIC T5-T1 Gb (ISO 80079-36)

Refer to the individual Temperature Limits table for the temperatures permitted for the individual pump variants. (⇒ Section 2.9.2, Page 11)

The pump complies with the requirements of type of protection constructional safety "c" to ISO 80079-37.

Shaft coupling An EC manufacturer's declaration is required for the shaft coupling; the shaft coupling must be marked accordingly.

Motor The motor must be considered separately.

2.9.2 Temperature limits

In normal pump operation, the highest temperatures are to be expected on the surface of the pump casing, at the shaft seal and in the bearing areas.

The surface temperature at the pump casing corresponds to the temperature of the fluid handled. If the pump is heated in addition, the operator of the system is responsible for observing the specified temperature class and fluid temperature (operating temperature).

The table below lists the temperature classes and the resulting theoretical temperature limits of the fluid handled (a possible temperature rise in the shaft seal area has already been taken into account).

The temperature class specifies the maximum permissible temperature at the surface of the pump set during operation.

For the permissible operating temperature of the pump in question refer to the data sheet.

Table 4: Temperature limits

Temperature class to EN 13463-1 or ISO 80079-36	Maximum permissible fluid temperature
T1	Temperature limit of the pump
T2	280 °C
T3	185 °C
T4	120 °C
T5	85 °C
T6	Only after consultation with the manufacturer

In the following cases and if ambient temperatures are higher, contact the manufacturer.

Temperature class T5 Compliance with temperature class T5 is warranted for the area of the rolling element bearings based on an ambient temperature of 40 °C, assuming that the pump set is properly serviced and operated and that the surfaces in the bearing area are freely exposed to the atmosphere.

Temperature class T6 If temperature class and T6 has to be complied with, special measures may have to be taken with regard to the bearing temperature.

Misuse, malfunctions or non-compliance with the instructions may result in substantially higher temperatures.

If the pump is to be operated at a higher temperature, if there is no data sheet or if the pump is part of a pool of pumps, contact KSB for the maximum permissible operating temperature.

2.9.3 Monitoring equipment

The pump (set) must only be operated within the limits specified in the data sheet and on the name plate.

If the system operator cannot warrant compliance with these operating limits, appropriate monitoring devices must be used.

Check whether monitoring equipment is required to ensure that the pump set functions properly.

Contact KSB for further information about monitoring equipment.

2.9.4 Operating limits

The minimum flows indicated in (⇒ Section 6.2.3.1, Page 44) refer to water and water-like fluids handled. Longer operating periods with these fluids and at the flow rates indicated will not cause an additional increase in the temperatures at the pump surface. However, if the physical properties of the fluids handled are different from water, it is essential to check whether an additional heat build-up may occur and if the minimum flow rate must therefore be increased. The calculation formula in (⇒ Section 6.2.3.1, Page 44) can be used to check whether additional heat build-up may lead to a dangerous temperature increase at the pump surface.

3 Transport/Temporary Storage/Disposal

3.1 Checking the condition upon delivery

1. On transfer of goods, check each packaging unit for damage.
2. In the event of in-transit damage, assess the exact damage, document it and notify KSB or the supplying dealer and the insurer about the damage in writing immediately.

3.2 Transport

	DANGER
	<p>The pump (set) could slip out of the suspension arrangement Danger to life from falling parts!</p> <ul style="list-style-type: none"> ▷ Always transport the pump (set) in the specified position. ▷ Never attach the suspension arrangement to the free shaft end or the motor eyebolt. ▷ Observe the information about weights, centre of gravity and fastening points. ▷ Observe the applicable local accident prevention regulations. ▷ Use suitable, permitted lifting accessories, e.g. self-tightening lifting tongs.

To transport the pump/pump set or back pull-out unit suspend it from the lifting tackle as shown.

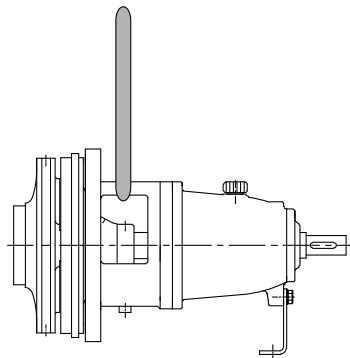

Fig. 1: Transporting the back pull-out unit

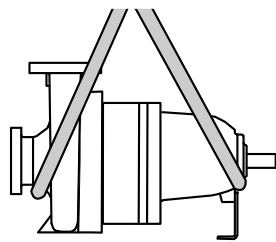

Fig. 2: Transporting the pump

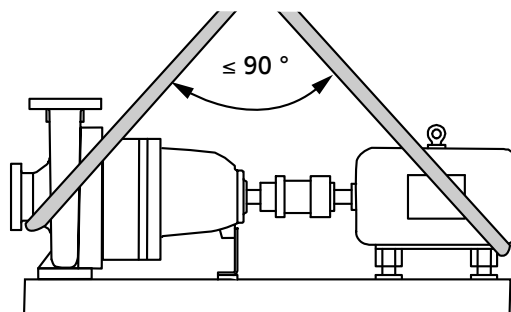

Fig. 3: Transporting the pump set

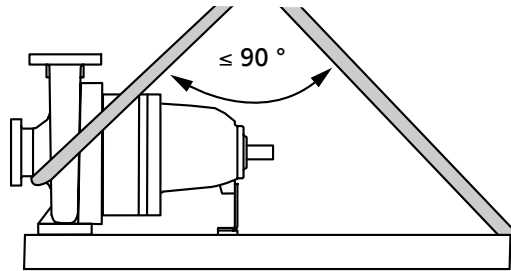

Fig. 4: Transporting the pump on the baseplate

3.3 Storage/preservation

If commissioning is to take place some time after delivery, we recommend that the following measures be taken for pump (set) storage.

	<p style="background-color: #FFD700; padding: 5px;">CAUTION</p> <p>Damage during storage due to humidity, dirt or vermin Corrosion/contamination of the pump (set)!</p> <ul style="list-style-type: none"> ▷ For outdoor storage cover the pump (set) or the packaged pump (set) and accessories with waterproof material.
	<p style="background-color: #FFD700; padding: 5px;">CAUTION</p> <p>Wet, contaminated or damaged openings and connections Leakage or damage to the pump!</p> <ul style="list-style-type: none"> ▷ Clean and cover pump openings and connections as required prior to putting the pump into storage.

Store the pump (set) in a dry, protected room where the atmospheric humidity is as constant as possible.

Rotate the shaft by hand once a month, e.g. via the motor fan.

If properly stored indoors, the pump set is protected for a maximum of 12 months. New pumps/pump sets are supplied by our factory duly prepared for storage.



For storing a pump (set) which has already been operated, the shutdown measures must be adhered to. (⇒ Section 6.3.1, Page 44)

3.4 Return to supplier

1. Drain the pump as per operating instructions. (⇒ Section 7.3, Page 53)
2. Flush and clean the pump, particularly if it has been used for handling noxious, explosive, hot or other hazardous fluids.
3. If the pump has handled fluids whose residues could lead to corrosion damage in the presence of atmospheric humidity or could ignite upon contact with oxygen also neutralise the pump and blow through with anhydrous inert gas to ensure drying.
4. Always complete and enclose a certificate of decontamination when returning the pump.
Indicate any safety measures and decontamination measures taken.
(⇒ Section 11, Page 78)

	<p style="background-color: #0070C0; color: white; padding: 5px;">NOTE</p> <p>If required, a blank certificate of decontamination can be downloaded from the following web site: www.ksb.com/certificate_of_decontamination</p>
--	--

3.5 Disposal

	 WARNING
	<p>Fluids handled, consumables and supplies which are hot and/or pose a health hazard</p> <p>Hazard to persons and the environment!</p> <ul style="list-style-type: none">▷ Collect and properly dispose of flushing fluid and any fluid residues.▷ Wear safety clothing and a protective mask if required.▷ Observe all legal regulations on the disposal of fluids posing a health hazard.

1. Dismantle the pump (set).
Collect greases and other lubricants during dismantling.
2. Separate and sort the pump materials, e.g. by:
 - Metals
 - Plastics
 - Electronic waste
 - Greases and other lubricants
3. Dispose of materials in accordance with local regulations or in another controlled manner.

4 Description of the Pump (Set)

4.1 General description

- Standardised water pump with shaft seal
- Handling clean or aggressive fluids not chemically and mechanically aggressive to the pump materials.

4.2 Product Information as per Regulation No. 547/2012 (for water pumps with a maximum shaft power of 150 kW) implementing "Ecodesign" Directive 2009/125/EC

- Minimum efficiency index: see name plate, key to name plate
- The benchmark for the most efficient water pumps is $MEI \geq 0.70$.
- Year of construction: see name plate, key to name plate
- Manufacturer's name or trade mark, commercial registration number and place of manufacture: see data sheet or order documentation
- Product's type and size identifier: see name plate, key to name plate
- Hydraulic pump efficiency (%) with trimmed impeller: see data sheet
- Pump performance curves, including efficiency characteristics: see documented characteristic curve
- The efficiency of a pump with a trimmed impeller is usually lower than that of a pump with full impeller diameter. Trimming of the impeller will adapt the pump to a fixed duty point, leading to reduced energy consumption. The minimum efficiency index (MEI) is based on the full impeller diameter.
- Operation of this water pump with variable duty points may be more efficient and economic when controlled, for example, by the use of a variable speed drive that matches the pump duty to the system.
- Information on dismantling, recycling and disposal after decommissioning: (⇒ Section 3.5, Page 15)
- Information on benchmark efficiency or benchmark efficiency graph for $MEI = 0.70$ (0.40) for the pump based on the model shown in the Figure are available at: <http://www.europump.org/efficiencycharts>

4.3 Designation

Table 5: Designation example

Position																																				
1	2	3	4	5	6	7	8	9	10	11	12	13	14	15	16	17	18	19	20	21	22	23	24	25	26	27	28	29	30	31	32	33	34	35	36	37
E	T	N		0	5	0	-	0	3	2	-	1	2	5	1	G	G	S	A	S	1	1	G	B	2	1	3	2	0	2	B	P	D	2	E	M
See name plate and data sheet																									See data sheet											

Table 6: Designation key

Position	Code	Description
1-4	Pump type	
	ETN	Etanorm
	ETNF	Etanorm Feuerlöschpumpe
5-16	Size, e.g.	
	050	Nominal suction nozzle diameter [mm]
	032	Nominal discharge nozzle diameter [mm]
	1251	Nominal impeller diameter [mm]
17	Pump casing material	
	B	Bronze CC480K-GS / B30 C90700
	C	Stainless steel 1.4408 / A743CF8M
	G	Cast iron EN-GJL-250 / A48CL35

Position	Code	Description	
17	S	Nodular cast iron	EN-GJS-400-15
18	Impeller material		
	B	Bronze	CC480K-GS / B30 C90700
	C	Stainless steel	1.4408 / A743CF8M
	G	Cast iron	EN-GJL-250 / A48CL35
	I	Bronze ²⁾	IS318 LTB
	O	Cast steel	1.4008 / A743CF8M
	S	Nodular cast iron	EN-GJS-400-15
19	Design		
	A	Fire-fighting variant to APSAD	
	H	Approved for drinking water to ACS	
	K	Approved for drinking water to KSB Standard	
	M	Fire-fighting variant to FM	
	N	Fire-fighting variant, non-listed	
	S	Standard	
	U	Approved for drinking water to UBA	
	V	Fire-fighting variant to VDS	
	W	Approved for drinking water to WRAS	
X	Non-standard (BT3D, BT3)		
20	Casing cover		
	A	Conical cover for version with single mechanical seal	
	C	Cylindrical cover for version with gland packing or double mechanical seal	
21	Shaft seal type		
	A	Conical cover without internal circulation	
	D	Double mechanical seal in back-to-back arrangement	
	E	External circulation	
	F	External flushing	
	I	Internal circulation (only for version with conical cover)	
	P	Gland packing	
	S	Internal circulation, discharge cover with anti-swirl baffles (only for version with conical cover)	
T	Double mechanical seal in tandem arrangement with internal circulation		
22-23	Seal code of gland packing		
	1A	P1, with internal barrier fluid (Na), material RT/P (for hot water of up to 120 °C)	
	1B	P2, without barrier fluid (Nb), material RT/P (for hot water of up to 120 °C)	
	1C	P3, with external barrier fluid (Nc), material RT/P (for hot water of up to 110 °C)	
	1D	P4, with external flushing liquid (VSH), material RT/P (for hot water of up to 110 °C)	
	3B	P2, without barrier fluid (Nb), material BUP901/B5 (for hot water of up to 140 °C)	
	4A	P1, with internal barrier fluid (Na), material BU5426 (for drinking water to ACS, for example)	
	4B	P2, without barrier fluid (Nb), material BU5426 (for drinking water to ACS, for example)	

2) Only applicable to Indian sites

Position	Code	Description	
22-23	5A	P1, with internal barrier fluid (Na), material HE1727 (surface treatment technology)	
	5B	P2, without barrier fluid (Nb), material HE1727 (surface treatment technology)	
	Seal code, single mechanical seal		
	01	Q1Q1VGG	1 (ZN1181)
	06	U3BEGG	RMG13G606
	07	Q1Q1EGG	1A (ZN1181)
	08	AQ1VGG	M32N69
	09	U3U3VGG	MG13G60
	10	Q1Q1X4GG	1 (ZN1181)
	11	BQ1EGG-WA	1 (ZN1181)
	12	Q12Q1M1GG	M37GN83
	13	BQ1VGG	1 (ZN1181)
	14	Q1Q1KY7G	KMB13S2G9
	15	Q1Q1K9GG/G	M7G49
	16	BVPGG	MG1S20
	17	Q1BVGG	M7N / 5A
	22	AQ1EGG	M32N69
	66	Q7Q7EGG	MG13G6
	67	Q6Q6X4GG	MG13G60 / MG1G61S6
	Seal code, double mechanical seal in tandem arrangement		
	18	Q1Q1EGG/G	MG12G6-E1
		Q1Q1EGG-G	MG12G6-E1
	19	Q1Q1M1GG	HN400N
		Q1Q1EGG-G	MG12G6-E1
	20	Q12Q1M1GG1	M37GN85
		Q1Q1EGG-G	MG12G6-E1
	23	Q12Q1M1GG1	M37GN92
		Q1Q1EGG-G	MG12G6-E1
	Seal code, double mechanical seal in back-to-back arrangement		
	21	Q1Q1K9GG	M7G49
		Q1Q1K9GG	M7G49
	24	Q1Q1K9GG	M7G49
		Q1BVGG	M7N
24	Bearing bracket		
	G	Grease lubrication	
	O	Oil lubrication	
25	Scope of supply		
	A	Pump only (Fig. 0 bare-shaft pump)	
	B	Pump, baseplate	
	C	Pump, baseplate, coupling, coupling guard	
	D	Pump, baseplate, coupling, coupling guard, motor	
26	Shaft unit		
	2	Shaft unit 25, bearing bracket LS (standard)	
	3	Shaft unit 35, bearing bracket LS (standard)	
	4	Shaft unit 50, bearing bracket LR (reinforced)	
	5	Shaft unit 55, bearing bracket LS (standard)	
	6	Shaft unit 60, bearing bracket LR (reinforced)	
	7	Shaft unit 60.1	

Position	Code	Description
27-30	Motor rating P_N [kW]	
	0007	0,75

	1320	132,00
31	Number of motor poles	
32	Product generation	
	B	Etanorm 2013
33-36	Design	
	-	Fixed-speed version
	PD2	Variable speed version, with PumpDrive 2
	PD2E	Variable speed version, with PumpDrive 2 Eco
	IFS	MyFlow Drive
37	PumpMeter	
	M	PumpMeter

4.4 Name plate

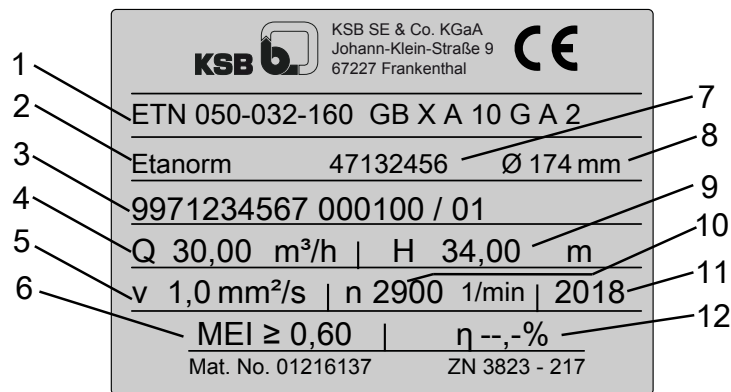

Fig. 5: Name plate (example) Etanorm

1	Type series code, size and version	2	Type series
3	KSB order No., order item No. and consecutive No.	4	Flow rate
5	Kinematic viscosity of the fluid handled	6	Minimum efficiency index
7	Material number (if applicable)	8	Impeller diameter
9	Head	10	Speed
11	Year of construction	12	Efficiency (see data sheet)

4.5 Design details

Design

- Volute casing pump
- Horizontal installation
- Back pull-out design
- Single-stage
- Dimensions and ratings to EN 733

Pump casing

- Radially split volute casing
- Volute casing with integrally cast pump feet
- Replaceable casing wear rings (optional for casing material C)

Impeller type

- Closed radial impeller with multiply curved vanes

Bearings

- Standard bearings
 - Floating bearings: deep groove ball bearings
- Reinforced bearings
 - Floating bearings: deep groove ball bearings
- Bearings with bearing pedestal
 - Floating bearings: deep groove ball bearings

Shaft seal

- Gland packing
- Single mechanical seals and double mechanical seals to EN 12756
- Shaft equipped with replaceable shaft sleeve in the shaft seal area

Example: WS_25_LS
Table 7: Bearing bracket designation

Code	Description
WS	Standardised water pump bearing bracket
25	Size code (based on dimensions of seal chamber and shaft end)
LS	Standard
LR	Reinforced

Bearings used:

Table 8: Standard bearing assembly

Version	Bearing bracket	Rolling element bearings	
		Pump end	Drive end
Standard bearing assembly (grease lubrication)	WS_25_LS	6305 2Z C3	6305 2Z C3
	WS_35_LS	6307 2Z C3	6307 2Z C3
	WS_55_LS	6311 2Z C3	6311 2Z C3
Standard bearing assembly (oil lubrication)	WS_25_LS	6305 C3	6305 C3
	WS_35_LS	6307 C3	6307 C3
	WS_55_LS	6311 C3	6311 C3
Reinforced bearing assembly (grease lubrication)	WS_50_LR	6310 2Z C3	6310 2Z C3
	WS_60_LR	6312 2Z C3	6312 2Z C3
Reinforced bearing assembly (oil lubrication)	WS_50_LR	6310 C3	6310 C3
	WS_60_LR	6312 C3	6312 C3
Standard bearing pedestal (grease lubrication)	WS_25_PS	-	-
	WS_35_PS	-	-
	WS_55_PS	-	-
Standard bearing pedestal (oil lubrication)	WS_25_PS	-	-
	WS_35_PS	-	-
	WS_55_PS	-	-

Lubrication:

- Grease lubrication
- Oil lubrication

4.6 Configuration and function

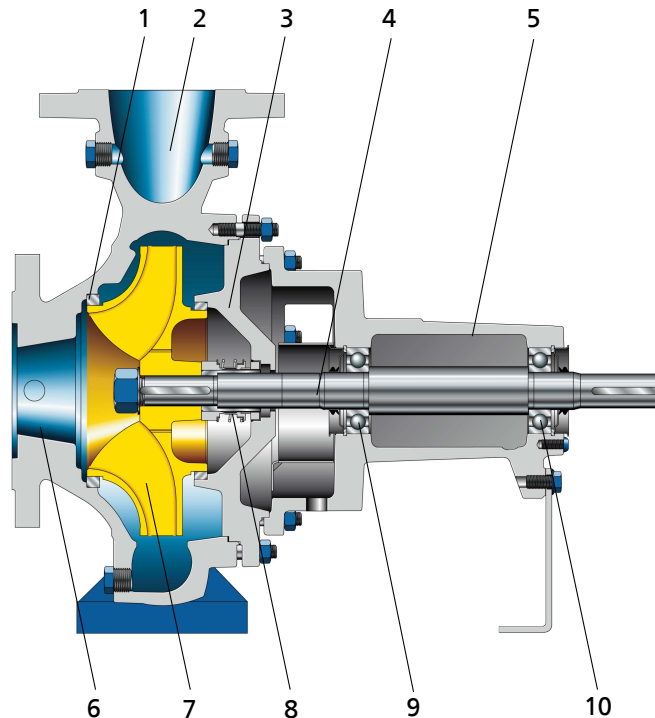

Fig. 6: Sectional drawing

1	Clearance gap	2	Discharge nozzle
3	Casing cover	4	Shaft
5	Bearing bracket	6	Suction nozzle
7	Impeller	8	Shaft seal
9	Rolling element bearing, pump end	10	Rolling element bearing, motor end

Design The pump is designed with an axial fluid inlet and a radial outlet. The hydraulic system runs in its own bearings and is connected to the motor by a shaft coupling.

Function The fluid enters the pump axially via the suction nozzle (6) and is accelerated outward by the rotating impeller (7). In the flow passage of the pump casing the kinetic energy of the fluid is converted into pressure energy. The fluid is pumped to the discharge nozzle (2), where it leaves the pump. The clearance gap (1) prevents any fluid from flowing back from the casing to the suction nozzle. At the rear side of the impeller, the shaft (4) enters the casing via the casing cover (3). The shaft passage through the cover is sealed to atmosphere with a shaft seal (8). The shaft runs in rolling element bearings (9 and 10), which are supported by a bearing bracket (5) linked with the pump casing and/or casing cover.

Sealing The pump is sealed by a shaft seal (standardised mechanical seal or gland packing).

4.7 Noise characteristics

 Table 9: Surface sound pressure level L_{pA} ³⁾⁴⁾

Rated power input P_N [kW]	Pump			Pump set		
	960 rpm [dB]	1450 rpm [dB]	2900 rpm [dB]	960 rpm [dB]	1450 rpm [dB]	2900 rpm [dB]
0,55	46	47	48	54	55	64
0,75	48	48	50	55	56	66
1,1	49	50	52	56	57	66
1,5	51	52	54	56	58	67
2,2	53	54	56	58	59	67
3	54	55	57	59	60	68
4	56	57	59	60	61	68
5,5	58	59	61	61	62	70
7,5	59	60	62	63	64	71
11	61	62	64	64	65	73
15	63	64	66	66	67	74
18,5	64	65	67	67	68	75
22	65	66	68	68	69	76
30	66	67	70	69	70	77
37	67	68	71	70	71	78
45	68	69	72	71	73	78
55	69	70	73	72	74	79
75	-	72	75	-	75	80
90	-	73	76	-	76	81
110	-	74	77	-	77	81
132	-	76	78	-	77	83
160	-	77	79	-	78	84
200	-	-	80	-	-	84

4.8 Dimensions and weights

For dimensions and weights please refer to the general arrangement drawing/outline drawing of the pump/pump set.

4.9 Scope of supply



Depending on the model, the following items are included in the scope of supply:

- Pump
- Baseplate
- Coupling
- Coupling guard
- Drive

3) Surface sound pressure level; as per ISO 3744 and EN 12639; valid for pump operation in the $Q/Q_{opt} = 0.8 - 1.1$ range and for non-cavitating operation. If noise levels are to be guaranteed: Add +3 dB for measuring and constructional tolerance.
 4) Increase for 60 Hz operation: 3500 rpm: +3 dB, 1750 rpm: +1 dB



5 Installation at Site

5.1 Safety regulations

	 DANGER
	<p>Excessive temperatures in the shaft seal area Explosion hazard!</p> <ul style="list-style-type: none"> ▷ Never operate a pump (set) with gland packing in potentially explosive atmospheres.

5.2 Checks to be carried out prior to installation



Place of installation



	 WARNING
	<p>Installation on mounting surface which is unsecured and cannot support the load Personal injury and damage to property!</p> <ul style="list-style-type: none"> ▷ Use a concrete of compressive strength class C12/15 which meets the requirements of exposure class XC1 to EN 206-1. ▷ The mounting surface must be set, flat, and level. ▷ Observe the weights indicated.

1. Check the structural requirements.
All structural work required must have been prepared in accordance with the dimensions stated in the outline drawing/general arrangement drawing.

5.3 Installing the pump set

Always install the pump set in horizontal position.

	 DANGER
	<p>Excessive temperatures due to improper installation Explosion hazard!</p> <ul style="list-style-type: none"> ▷ Install the pump in a horizontal position to ensure self-venting of the pump.

	 DANGER
	<p>Static charging due to insufficient potential equalisation Explosion hazard!</p> <ul style="list-style-type: none"> ▷ Make sure that the connection between pump and baseplate is electrically conductive.

5.3.1 Installation on the foundation

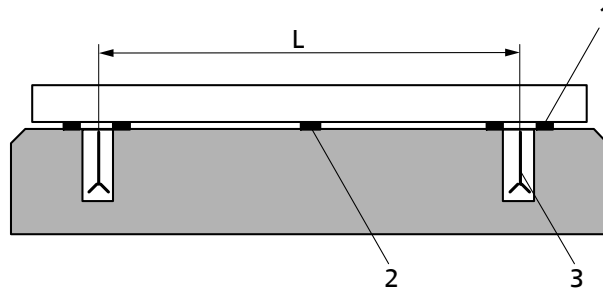

Fig. 7: Fitting the shims

L	Bolt-to-bolt distance	1	Shim
2	Shim if (L) > 800 mm	3	Foundation bolt

- ✓ The foundation has the required strength and characteristics.
 - ✓ The foundation has been prepared in accordance with the dimensions given in the outline drawing/general arrangement drawing.
1. Position the pump set on the foundation and level it with the help of a spirit level placed on the shaft and discharge nozzle.
Permissible deviation: 0.2 mm/m
 2. Use shims (1) for height compensation, if necessary.
Always fit shims, if any, immediately to the left and right of the foundation bolts (3) between the baseplate/foundation frame and the foundation.
For a bolt-to-bolt distance (L) > 800 mm fit additional shims (2) halfway between the bolt holes.
All shims must lie perfectly flush.
 3. Insert the foundation bolts (3) into the holes provided.
 4. Use concrete to set the foundation bolts (3) into the foundation.
 5. Wait until the concrete has set firmly, then level the baseplate.
 6. Tighten the foundation bolts (3) evenly and firmly.

	<p>NOTE</p> <p>For baseplates more than 400 mm wide grouting the baseplate with low-shrinkage concrete is recommended.</p>
	<p>NOTE</p> <p>For baseplates made of grey cast iron grouting the baseplate with low-shrinkage concrete is recommended.</p>
	<p>NOTE</p> <p>For low-noise operation contact the manufacturer to check whether the pump set can be installed on anti-vibration mounts.</p>
	<p>NOTE</p> <p>Expansion joints can be fitted between the pump and the suction/discharge line.</p>

5.3.2 Installation without foundation

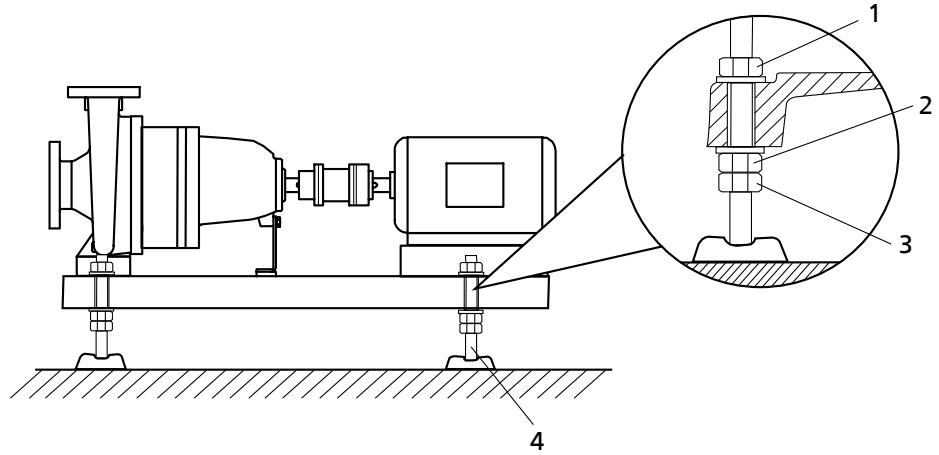

Fig. 8: Adjusting the levelling elements

1, 3	Locknut	2	Adjusting nut
4	Machine mount		

- ✓ The installation surface has the required strength and characteristics.
- 1. Position the pump set on the machine mounts (4) and align it with the help of a spirit level (on the shaft/discharge nozzle).
- 2. To adjust any differences in height, loosen the locknuts (1, 3) of the machine mounts (4).
- 3. Turn the adjusting nut (2) until any differences in height have been compensated.
- 4. Re-tighten the locknuts (1, 3) at the machine mounts (4).

5.4 Piping

5.4.1 Connecting the piping

	<p>! DANGER</p>
	<p>Impermissible loads acting on the pump nozzles Danger to life from escaping hot, toxic, corrosive or flammable fluids!</p> <ul style="list-style-type: none"> ▷ Do not use the pump as an anchorage point for the piping. ▷ Anchor the pipes in close proximity to the pump and connect them properly without transmitting any stresses or strains. ▷ Observe the permissible forces and moments at the pump nozzles. ▷ Take appropriate measures to compensate for thermal expansion of the piping.
	<p>CAUTION</p>
	<p>Incorrect earthing during welding work at the piping Destruction of rolling element bearings (pitting effect)!</p> <ul style="list-style-type: none"> ▷ Never earth the electric welding equipment on the pump or baseplate. ▷ Prevent current flowing through the rolling element bearings.

	NOTE
	<p>Installing check and shut-off elements in the system is recommended, depending on the type of plant and pump. However, such elements must not obstruct proper drainage or hinder disassembly of the pump.</p>

- ✓ Suction lift lines have been laid with a rising slope, suction head lines with a downward slope towards the pump.
- ✓ A flow stabilisation section having a length equivalent to at least twice the diameter of the suction flange has been provided upstream of the suction flange.
- ✓ The nominal diameters of the pipelines are at least equal to the nominal diameters of the pump nozzles.
- ✓ Adapters to larger diameters have a diffuser angle of approximately 8° to prevent excessive pressure losses.
- ✓ The pipelines have been anchored in close proximity to the pump and connected without transmitting any stresses or strains.

	CAUTION
	<p>Welding beads, scale and other impurities in the piping Damage to the pump!</p> <ul style="list-style-type: none"> ▷ Remove any impurities from the piping. ▷ If necessary, install a filter. ▷ Observe the information in (⇒ Section 7.2.2.3, Page 49) .

1. Thoroughly clean, flush and blow through all vessels, pipelines and connections (especially of new installations).
2. Before installing the pump in the piping, remove the flange covers on the suction and discharge nozzles of the pump.
3. Check that the inside of the pump is free from any foreign objects. Remove any foreign objects.
4. If required, install a filter in the piping (see figure: Filter in the piping).

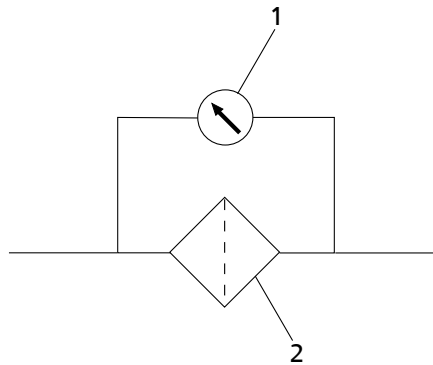

Fig. 9: Filter in the piping

1	Differential pressure gauge	2	Filter
---	-----------------------------	---	--------

	NOTE
	<p>Use a filter with laid-in wire mesh (mesh width 0.5 mm, wire diameter 0.25 mm) of corrosion-resistant material. Use a filter with a filter area three times the cross-section of the piping. Conical filters have proved suitable.</p>

5. Connect the pump nozzles to the piping.

	CAUTION
	<p>Aggressive flushing liquid and pickling agent Damage to the pump!</p> <p>▷ Match the cleaning operation mode and duration of flushing and pickling to the casing materials and seal materials used.</p>

5.4.2 Permissible forces and moments at the pump nozzles

The data on forces and moments apply to static pipelines only. The values are only applicable if the pump is installed on a baseplate and bolted to a rigid and level foundation.

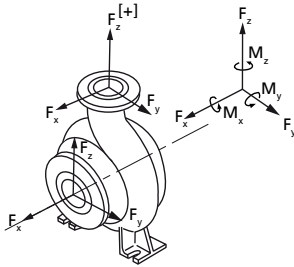

Fig. 10: Forces and moments at the pump nozzles

Table 10: Forces and moments at the pump nozzles for casing material G (JL1040/ A48CL35B)

Size	Suction nozzle								Discharge nozzle							
	DN	Fx	Fy	Fz	∑F	Mx	My	Mz	DN	Fx	Fy	Fz	∑F	Mx	My	Mz
		[N]	[N]	[N]	[N]	[Nm]	[Nm]	[Nm]		[N]	[N]	[N]	[N]	[Nm]	[Nm]	[Nm]
040-025-160	40	450	400	350	696	450	320	370	25	265	250	300	472	315	210	245
040-025-200	40	450	400	350	696	450	320	370	25	265	250	300	472	315	210	245
050-032-125.1	50	580	530	470	916	500	350	400	32	320	300	370	574	390	265	300
050-032-160.1	50	580	530	470	916	500	350	400	32	320	300	370	574	390	265	300
050-032-200.1	50	580	530	470	916	500	350	400	32	320	300	370	574	390	265	300
050-032-250.1	50	580	530	470	916	500	350	400	32	320	300	370	574	390	265	300
050-032-125	50	580	530	470	916	500	350	400	32	320	300	370	574	390	265	300
050-032-160	50	580	530	470	916	500	350	400	32	320	300	370	574	390	265	300
050-032-200	50	580	530	470	916	500	350	400	32	320	300	370	574	390	265	300
050-032-250	50	580	530	470	916	500	350	400	32	320	300	370	574	390	265	300
065-040-125	65	740	650	600	1153	530	390	420	40	400	350	450	696	450	320	370
065-040-160	65	740	650	600	1153	530	390	420	40	400	350	450	696	450	320	370
065-040-200	65	740	650	600	1153	530	390	420	40	400	350	450	696	450	320	370
065-040-250	65	740	650	600	1153	530	390	420	40	400	350	450	696	450	320	370
065-040-315	65	740	650	600	1153	530	390	420	40	400	350	450	696	450	320	370
065-050-125	65	740	650	600	1153	530	390	420	50	530	470	580	916	500	350	400
065-050-160	65	740	650	600	1153	530	390	420	50	530	470	580	916	500	350	400
065-050-200	65	740	650	600	1153	530	390	420	50	530	470	580	916	500	350	400
065-050-250	65	740	650	600	1153	530	390	420	50	530	470	580	916	500	350	400
065-050-315	65	740	650	600	1153	530	390	420	50	530	470	580	916	500	350	400
080-065-125	80	880	790	720	1385	560	400	460	65	650	600	740	1153	530	390	420
080-065-160	80	880	790	720	1385	560	400	460	65	650	600	740	1153	530	390	420
080-065-200	80	880	790	720	1385	560	400	460	65	650	600	740	1153	530	390	420
080-065-250	80	880	790	720	1385	560	400	460	65	650	600	740	1153	530	390	420
080-065-315	80	880	790	720	1385	560	400	460	65	650	600	740	1153	530	390	420
100-080-160	100	1180	1050	950	1843	620	440	510	80	790	720	880	1385	560	400	460
100-080-200	100	1180	1050	950	1843	620	440	510	80	790	720	880	1385	560	400	460
100-080-250	100	1180	1050	950	1843	620	440	510	80	790	720	880	1385	560	400	460

Size	Suction nozzle								Discharge nozzle							
	DN	Fx	Fy	Fz	ΣF	Mx	My	Mz	DN	Fx	Fy	Fz	ΣF	Mx	My	Mz
		[N]	[N]	[N]	[N]	[Nm]	[Nm]	[Nm]		[N]	[N]	[N]	[N]	[Nm]	[Nm]	[Nm]
100-080-315	100	1180	1050	950	1843	620	440	510	80	790	720	880	1385	560	400	460
100-080-400	100	1180	1050	950	1843	620	440	510	80	790	720	880	1385	560	400	460
125-100-160	125	1400	1250	1120	2186	740	530	670	100	1050	950	1180	1843	620	440	510
125-100-200	125	1400	1250	1120	2186	740	530	670	100	1050	950	1180	1843	620	440	510
125-100-250	125	1400	1250	1120	2186	740	530	670	100	1050	950	1180	1843	620	440	510
125-100-315	125	1400	1250	1120	2186	740	530	670	100	1050	950	1180	1843	620	440	510
125-100-400	125	1400	1250	1120	2186	740	530	670	100	1050	950	1180	1843	620	440	510
150-125-200	150	1750	1600	1400	2754	880	610	720	125	1250	1120	1400	2186	740	530	670
150-125-250	150	1750	1600	1400	2754	880	610	720	125	1250	1120	1400	2186	740	530	670
150-125-315	150	1750	1600	1400	2754	880	610	720	125	1250	1120	1400	2186	740	530	670
150-125-400	150	1750	1600	1400	2754	880	610	720	125	1250	1120	1400	2186	740	530	670
200-150-200	200	2350	2100	1900	3680	1150	800	930	150	1600	1400	1750	2754	880	610	720
200-150-250	200	2350	2100	1900	3680	1150	800	930	150	1600	1400	1750	2754	880	610	720
200-150-315	200	2350	2100	1900	3680	1150	800	930	150	1600	1400	1750	2754	880	610	720
200-150-400	200	2350	2100	1900	3680	1150	800	930	150	1600	1400	1750	2754	880	610	720

Correction coefficients depending on material and temperature (see diagram below).

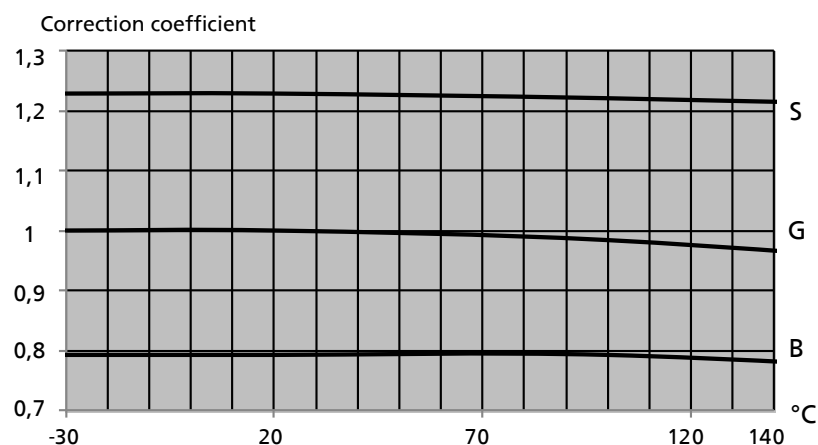



Fig. 11: Temperature/material correction diagram for casing materials G (EN-GJL-250/A48CL35B), S (EN-GJS-400-15/A536 GR 60-40-18) and B (CC480K-GS/B30 C90700)

Table 11: Forces and moments at the pump nozzles for casing material C (1.4408/ A743 GR CF8M)

Size	Suction nozzle								Discharge nozzle							
	DN	Fx	Fy	Fz	ΣF	Mx	My	Mz	DN	Fx	Fy	Fz	ΣF	Mx	My	Mz
		[N]	[N]	[N]	[N]	[Nm]	[Nm]	[Nm]		[N]	[N]	[N]	[N]	[Nm]	[Nm]	[Nm]
040-25-160	40	970	780	650	1404	500	280	410	25	460	410	600	860	370	185	280
040-25-200	40	970	780	650	1404	500	280	410	25	460	410	600	860	370	185	280
050-32-125.1	50	1240	1010	830	1802	650	320	500	32	650	500	780	1132	415	230	320
050-32-160.1	50	1240	1010	830	1802	650	320	500	32	650	500	780	1132	415	230	320
050-32-200.1	50	1240	1010	830	1802	650	320	500	32	650	500	780	1132	415	230	320
050-32-250.1	50	1240	1010	830	1802	650	320	500	32	650	500	780	1132	415	230	320
050-32-125	50	1240	1010	830	1802	650	320	500	32	650	500	780	1132	415	230	320
050-32-160	50	1240	1010	830	1802	650	320	500	32	650	500	780	1132	415	230	320
050-32-200	50	1240	1010	830	1802	650	320	500	32	650	500	780	1132	415	230	320
050-32-250	50	1240	1010	830	1802	650	320	500	32	650	500	780	1132	415	230	320
065-40-125	65	1600	1300	1050	2314	1050	550	780	40	780	640	1000	1421	500	280	415
065-40-160	65	1600	1300	1050	2314	1050	550	780	40	780	640	1000	1421	500	280	415

Size	Suction nozzle								Discharge nozzle							
	DN	Fx	Fy	Fz	∑F	Mx	My	Mz	DN	Fx	Fy	Fz	∑F	Mx	My	Mz
		[N]	[N]	[N]	[N]	[Nm]	[Nm]	[Nm]		[N]	[N]	[N]	[N]	[Nm]	[Nm]	[Nm]
065-40-200	65	1600	1300	1050	2314	1050	550	780	40	780	640	1000	1421	500	280	415
065-40-250	65	1600	1300	1050	2314	1050	550	780	40	780	640	1000	1421	500	280	415
065-40-315	65	1600	1300	1050	2314	1050	550	780	40	780	640	1000	1421	500	280	415
065-50-125	65	1600	1300	1050	2314	1050	550	780	50	1000	830	1250	1803	650	320	500
065-50-160	65	1600	1300	1050	2314	1050	550	780	50	1000	830	1250	1803	650	320	500
065-50-200	65	1600	1300	1050	2314	1050	550	780	50	1000	830	1250	1803	650	320	500
065-50-250	65	1600	1300	1050	2314	1050	550	780	50	1000	830	1250	1803	650	320	500
065-50-315	65	1600	1300	1050	2314	1050	550	780	50	1000	830	1250	1803	650	320	500
080-65-125	80	2000	1550	1300	2845	1330	690	1010	65	1300	1050	1600	2314	1050	550	790
080-65-160	80	2000	1550	1300	2845	1330	690	1010	65	1300	1050	1600	2314	1050	550	790
080-65-200	80	2000	1550	1300	2845	1330	690	1010	65	1300	1050	1600	2314	1050	550	790
080-65-250	80	2000	1550	1300	2845	1330	690	1010	65	1300	1050	1600	2314	1050	550	790
080-65-315	80	2000	1550	1300	2845	1330	690	1010	65	1300	1050	1600	2314	1050	550	790
100-80-160	100	2500	1950	1600	3551	1850	900	1400	80	1550	1300	1950	2810	1350	690	1000
100-80-200	100	2500	1950	1600	3551	1850	900	1400	80	1550	1300	1950	2810	1350	690	1000
100-80-250	100	2500	1950	1600	3551	1850	900	1400	80	1550	1300	1950	2810	1350	690	1000
100-80-315	100	2500	1950	1600	3551	1850	900	1400	80	1550	1300	1950	2810	1350	690	1000
100-80-400	100	2500	1950	1600	3551	1850	900	1400	80	1550	1300	1950	2810	1350	690	1000
125-100-160	125	3400	2700	2200	4867	2500	1300	1950	100	2000	1600	2500	3579	1850	900	1400
125-100-200	125	3400	2700	2200	4867	2500	1300	1950	100	2000	1600	2500	3579	1850	900	1400
125-100-250	125	3400	2700	2200	4867	2500	1300	1950	100	2000	1600	2500	3579	1850	900	1400
125-100-315	125	3400	2700	2200	4867	2500	1300	1950	100	2000	1600	2500	3579	1850	900	1400
125-100-400	125	3400	2700	2200	4867	2500	1300	1950	100	2000	1600	2500	3579	1850	900	1400
150-125-200	150	4300	3450	2850	6206	3200	1600	2450	125	2700	2200	3400	4867	2550	1300	1900
150-125-250	150	4300	3450	2850	6206	3200	1600	2450	125	2700	2200	3400	4867	2550	1300	1900
150-125-315	150	4300	3450	2850	6206	3200	1600	2450	125	2700	2200	3400	4867	2550	1300	1900
150-125-400	150	4300	3450	2850	6206	3200	1600	2450	125	2700	2200	3400	4867	2550	1300	1900
200-150-200	200	6750	5250	4300	9572	4850	2450	3550	150	3450	2850	4300	6206	3150	1600	2450
200-150-250	200	6750	5250	4300	9572	4850	2450	3550	150	3450	2850	4300	6206	3150	1600	2450
200-150-315	200	6750	5250	4300	9572	4850	2450	3550	150	3450	2850	4300	6206	3150	1600	2450
200-150-400	200	6750	5250	4300	9572	4850	2450	3550	150	3450	2850	4300	6206	3150	1600	2450

5.4.3 Vacuum balance line

	NOTE
	Where fluid has to be pumped out of a vessel under vacuum, installing a vacuum balance line is recommended.

The following rules apply to vacuum balance lines:

- Minimum nominal line diameter 25 mm.
- The line extends above the highest permissible fluid level in the vessel.

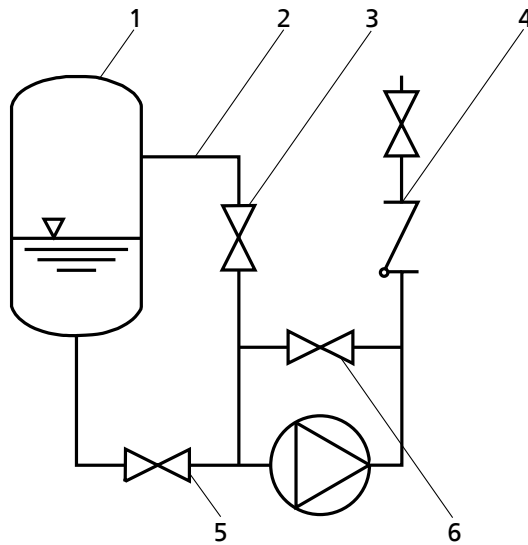

Fig. 12: Vacuum balance system

1	Vessel under vacuum	2	Vacuum balance line
3	Shut-off element	4	Swing check valve
5	Main shut-off element	6	Vacuum-tight shut-off element



	NOTE
	<p>An additional line fitted with a shut-off valve (from the pump discharge nozzle to the balance line) facilitates venting of the pump before start-up.</p>

5.4.4 Auxiliary connections



 	⚠ DANGER
	<p>Risk of potentially explosive atmosphere by mixing of incompatible fluids in the auxiliary piping</p> <p>Risk of burns!</p> <p>Explosion hazard!</p> <ul style="list-style-type: none"> ▷ Make sure that the barrier fluid or quench liquid are compatible with the fluid handled.

	⚠ WARNING
	<p>Failure to use or incorrect use of auxiliary connections (e.g. barrier fluid, flushing liquid, etc.)</p> <p>Risk of injury from escaping fluid!</p> <p>Risk of burns!</p> <p>Malfunction of the pump!</p> <ul style="list-style-type: none"> ▷ Refer to the general arrangement drawing, the piping layout and pump markings (if any) for the quantity, dimensions and locations of auxiliary connections. ▷ Use the auxiliary connections provided.

5.5 Enclosure/insulation

	<p style="background-color: #e67e22; color: white; padding: 5px;">⚠ DANGER</p> <p>Risk of potentially explosive atmosphere due to insufficient venting Explosion hazard!</p> <ul style="list-style-type: none"> ▷ Make sure the space between the casing cover/discharge cover and the bearing cover is sufficiently vented. ▷ Never close or cover the perforation of the bearing bracket guards (e.g. by insulation).
	<p style="background-color: #f1c40f; padding: 5px;">⚠ WARNING</p> <p>The volute casing and casing/discharge cover take on the same temperature as the fluid handled Risk of burns!</p> <ul style="list-style-type: none"> ▷ Insulate the volute casing. ▷ Fit protective equipment.
	<p style="background-color: #f1c40f; padding: 5px;">CAUTION</p> <p>Heat build-up in the bearing bracket Damage to the bearing!</p> <ul style="list-style-type: none"> ▷ Never insulate the bearing bracket, bearing bracket lantern and casing cover.

5.6 Checking the coupling alignment

 	<p style="background-color: #e67e22; color: white; padding: 5px;">⚠ DANGER</p> <p>Inadmissible temperatures at the coupling or bearings due to misalignment of the coupling Explosion hazard! Risk of burns!</p> <ul style="list-style-type: none"> ▷ Make sure that the coupling is correctly aligned at all times.
	<p style="background-color: #f1c40f; padding: 5px;">CAUTION</p> <p>Misalignment of pump and motor shafts Damage to pump, motor and coupling!</p> <ul style="list-style-type: none"> ▷ Always check the coupling after the pump has been installed and connected to the piping. ▷ Also check the coupling of pump sets supplied with pump and motor mounted on the same baseplate.

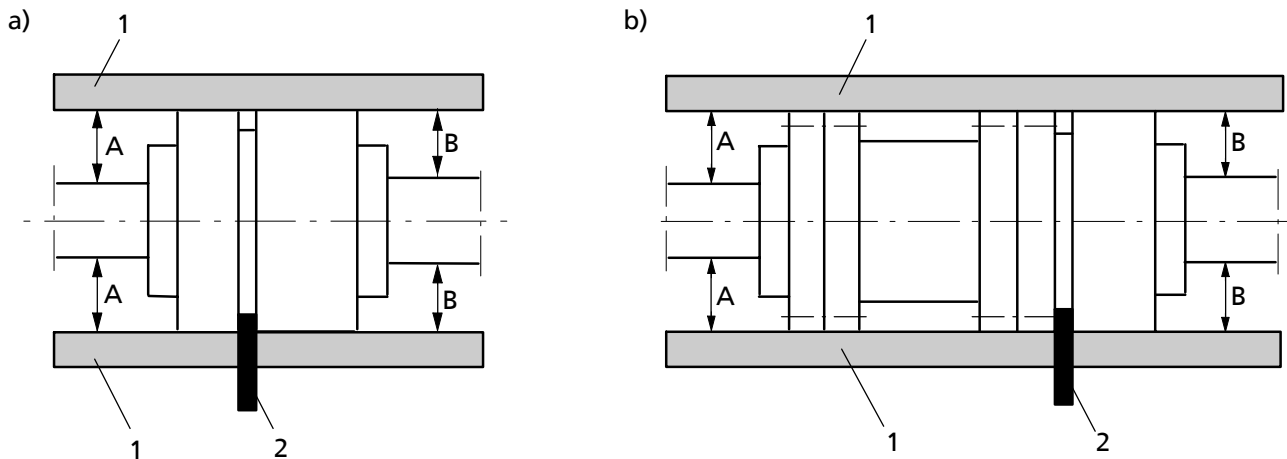

Fig. 13: Checking the coupling alignment: Coupling without spacer sleeve (a) or Coupling with spacer sleeve (b)

1	Straight-edge	2	Gauge
---	---------------	---	-------

- ✓ The coupling guard and its footboard, if any, have been removed.
 1. Loosen the support foot and re-tighten it without transmitting any stresses and strains.
 2. Place the straight-edge axially on both coupling halves.
 3. Leave the straight-edge in this position and turn the coupling by hand. The coupling is aligned correctly if the distances A and B to the respective shafts are the same at all points around the circumference. The radial and axial deviation between the two coupling halves must not exceed 0.1 mm, during standstill as well as at operating temperature and under inlet pressure.
 4. Check the distance (dimension see general arrangement drawing) between the two coupling halves around the circumference. The coupling is correctly aligned if the distance between the two coupling halves is the same at all points around the circumference. The radial and axial deviation between the two coupling halves must not exceed 0.1 mm, during standstill as well as at operating temperature and under inlet pressure.
 5. If alignment is correct, re-install the coupling guard and its footboard, if any.

Checking the coupling alignment with a laser tool

Coupling alignment may also be checked with a laser tool. Observe the documentation provided by the manufacturer of the measuring instrument.

5.7 Aligning the pump and motor

After having installed the pump set and connected the piping, check the coupling alignment and, if required, re-align the pump set (at the motor).

5.7.1 Motors with adjusting screw

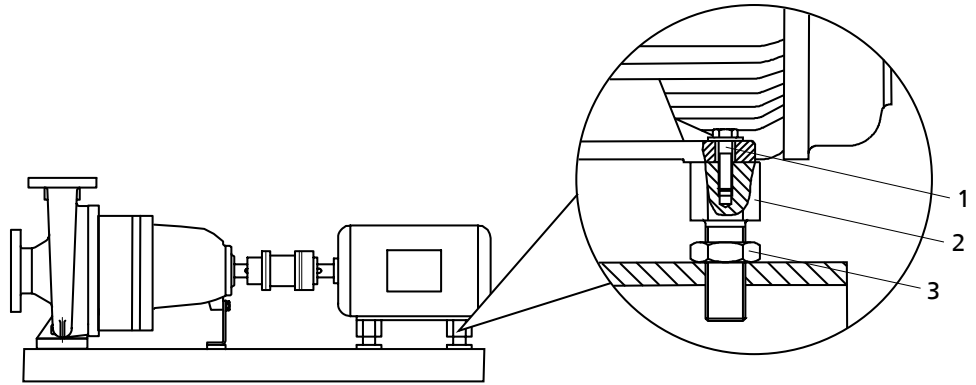

Fig. 14: Motor with adjusting screw

1	Hexagon head bolt	2	Adjusting screw
3	Locknut		

- ✓ The coupling guard and its footboard, if any, have been removed.
- 1. Check the coupling alignment.
- 2. Unscrew the hexagon head bolts (1) at the motor and the locknuts (3) at the baseplate.
- 3. Turn the adjusting screws (2) by hand or by means of an open-end wrench until the coupling alignment is correct and all motor feet rest squarely on the baseplate.
- 4. Re-tighten the hexagon head bolts (1) at the motor and the locknuts (3) at the baseplate.
- 5. Check proper functioning of coupling/shaft.
Check that coupling/shaft can easily be rotated by hand.

	<p>⚠ WARNING</p>
	<p>Unprotected rotating coupling Risk of injury by rotating shafts!</p> <ul style="list-style-type: none"> ▷ Always operate the pump set with a coupling guard. If the customer specifically requests not to include a coupling guard in KSB's delivery, then the operator must supply one! ▷ Observe all relevant regulations for selecting a coupling guard.
	<p>⚠ DANGER</p>
	<p>Risk of ignition by frictional sparks Explosion hazard!!</p> <ul style="list-style-type: none"> ▷ Choose a coupling guard material that is non-sparking in the event of mechanical contact.

- 6. Fit the coupling guard and its footboard, if any.
- 7. Check the distance between coupling and coupling guard.
The coupling guard must not touch the coupling.

5.7.2 Motors without adjusting screw

Any differences in the centreline heights of the pump and motor shafts are compensated by means of shims.

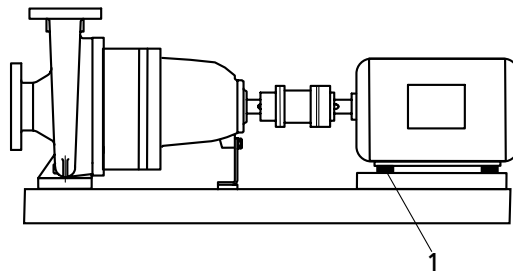

Fig. 15: Pump set with shim

1	Shim
---	------

- ✓ The coupling guard and its footboard, if any, have been removed.
 1. Check the coupling alignment.
 2. Loosen the hexagon head bolts at the motor.
 3. Insert shims underneath the motor feet until the difference in shaft centreline height has been compensated.
 4. Re-tighten the hexagon head bolts.
 5. Check proper functioning of coupling/shaft.
Check that coupling/shaft can easily be rotated by hand.

	<p>⚠ WARNING</p>
	<p>Unprotected rotating coupling Risk of injury by rotating shafts!</p> <ul style="list-style-type: none"> ▷ Always operate the pump set with a coupling guard. If the customer specifically requests not to include a coupling guard in KSB's delivery, then the operator must supply one! ▷ Observe all relevant regulations for selecting a coupling guard.

	<p>⚠ DANGER</p>
	<p>Risk of ignition by frictional sparks Explosion hazard!!</p> <ul style="list-style-type: none"> ▷ Choose a coupling guard material that is non-sparking in the event of mechanical contact.

6. Fit the coupling guard and its footboard, if any.
7. Check the distance between coupling and coupling guard.
The coupling guard must not touch the coupling.

5.8 Electrical connection

	<p>⚠ DANGER</p>
	<p>Electrical connection work by unqualified personnel Risk of fatal injury due to electric shock!</p> <ul style="list-style-type: none"> ▷ Always have the electrical connections installed by a trained and qualified electrician. ▷ Observe regulations IEC 60364 and, for explosion-proof models, EN 60079.

	⚠ WARNING
	<p>Incorrect connection to the mains Damage to the mains network, short circuit!</p> <ul style="list-style-type: none"> ▸ Observe the technical specifications of the local energy supply companies.

1. Check the available mains voltage against the data on the motor name plate.
2. Select an appropriate starting method.

	NOTE
	<p>A motor protection device is recommended.</p>

5.8.1 Setting the time relay

	CAUTION
	<p>Switchover between star and delta on three-phase motors with star-delta starting takes too long. Damage to the pump (set)!</p> <ul style="list-style-type: none"> ▸ Keep switch-over intervals between star and delta as short as possible.

Table 12: Time relay settings for star-delta starting:

Motor rating	Y time to be set
[kW]	[s]
≤ 30	< 3
> 30	< 5

5.8.2 Earthing





	⚠ DANGER
	<p>Electrostatic charging Explosion hazard! Damage to the pump set!</p> <ul style="list-style-type: none"> ▸ Connect the PE conductor to the earthing terminal provided. ▸ Provide for potential equalisation between the pump set and foundation.

5.8.3 Connecting the motor

	NOTE
	<p>In compliance with IEC 60034-8, three-phase motors are always wired for clockwise rotation (looking at the motor shaft stub). The pump's direction of rotation is indicated by an arrow on the pump.</p>

1. Match the motor's direction of rotation to that of the pump.
2. Observe the manufacturer's product literature supplied with the motor.

5.9 Checking the direction of rotation

	<p>⚠ DANGER</p> <p>Temperature increase resulting from contact between rotating and stationary components Explosion hazard! Damage to the pump set!</p> <ul style="list-style-type: none"> ▷ Never check the direction of rotation by starting up the unfilled pump set. ▷ Separate the pump from the motor to check the direction of rotation.
	<p>⚠ WARNING</p> <p>Hands inside the pump casing Risk of injuries, damage to the pump!</p> <ul style="list-style-type: none"> ▷ Always disconnect the pump set from the power supply and secure it against unintentional start-up before inserting your hands or other objects into the pump.
	<p>CAUTION</p> <p>Incorrect direction of rotation with non-reversible mechanical seal Damage to the mechanical seal and leakage!</p> <ul style="list-style-type: none"> ▷ Separate the pump from the motor to check the direction of rotation.
	<p>CAUTION</p> <p>Drive and pump running in the wrong direction of rotation Damage to the pump!</p> <ul style="list-style-type: none"> ▷ Refer to the arrow indicating the direction of rotation on the pump. ▷ Check the direction of rotation. If required, check the electrical connection and correct the direction of rotation.

The correct direction of rotation of the motor and pump is clockwise (seen from the drive end).

1. Start the motor and stop it again immediately to determine the motor's direction of rotation.
2. Check the direction of rotation.
The motor's direction of rotation must match the arrow indicating the direction of rotation on the pump.
3. If the motor is running in the wrong direction of rotation, check the electrical connection of the motor and switchgear, if any.

6 Commissioning/Start-up/Shutdown

6.1 Commissioning/Start-up

6.1.1 Prerequisites for commissioning/start-up

Before commissioning/starting up the pump set, make sure that the following conditions are met:

- The pump set has been mechanically connected as specified.
- The pump set has been properly connected to the power supply and is equipped with all protection devices. (⇒ Section 5.8, Page 34)
- The pump has been primed with the fluid to be handled. The pump has been vented.
- The direction of rotation has been checked. (⇒ Section 5.9, Page 36)
- All auxiliary connections required are connected and operational.
- The lubricants have been checked.
- After prolonged shutdown of the pump (set), the activities required for returning the equipment to service have been carried out. (⇒ Section 6.4, Page 45)

6.1.2 Filling in the lubricants

Grease-lubricated bearings

Grease-lubricated bearings have been packed with grease.

Oil-lubricated bearings



Fill the bearing bracket with lubricating oil.

Oil quality see (⇒ Section 7.2.3.1.2, Page 50)

Oil quantity see (⇒ Section 7.2.3.1.3, Page 51)

Filling the constant level oiler with lubricating oil (oil-lubricated bearings only)

- ✓ The constant level oiler has been fitted.

	<p>NOTE</p> <p>If no constant level oiler is provided on the bearing bracket, the oil level can be read in the middle of the oil level gauge arranged at the side of the bearing bracket.</p>
	<p>CAUTION</p> <p>Insufficient quantity of lubricating oil in the reservoir of the constant level oiler</p> <p>Damage to the bearings!</p> <ul style="list-style-type: none"> ▷ Regularly check the oil level. ▷ Always fill the oil reservoir completely. ▷ Keep the oil reservoir properly filled at all times.

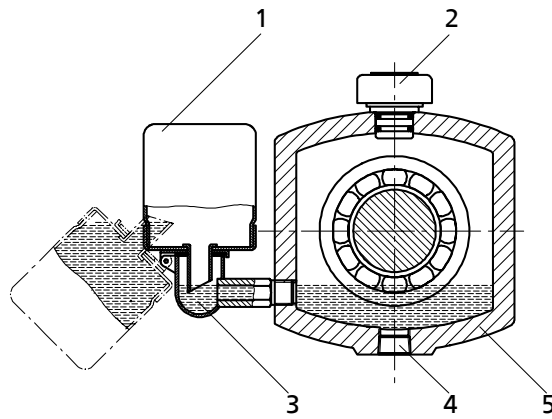

Fig. 16: Bearing bracket with constant level oiler





1	Constant level oiler	2	Vent plug
3	Connection elbow of the constant level oiler	4	Screw plug
5	Bearing bracket		

1. Pull out the vent plug (2).
2. Hinge down the reservoir of the constant level oiler (1) from the bearing bracket (5) and hold it in this position.
3. Fill in oil through the hole for the vent plug until the oil reaches the connection elbow of the constant level oiler (3).
4. Completely fill the reservoir of the constant level oiler (1).
5. Snap the constant level oiler (1) back into its operating position.
6. Fit the vent plug (2) again.
7. After approximately 5 minutes, check the oil level in the glass reservoir of the constant level oiler (1).
The oil reservoir must be properly filled at all times to ensure that the correct oil level is maintained. Repeat steps 1 - 6, if necessary.
8. To check the function of the constant level oiler (1), slowly drain some oil via the screw plug (4) until air bubbles can be seen in the oil reservoir.

	NOTE
	An excessively high oil level can lead to a temperature rise and to leakage of the fluid handled or oil.

6.1.3 Priming and venting the pump



	DANGER
	<p>Risk of potentially explosive atmosphere inside the pump Explosion hazard!</p> <ul style="list-style-type: none"> ▷ The pump internals in contact with the fluid to be handled, including the seal chamber and auxiliary systems must be filled with the fluid to be handled at all times. ▷ Provide sufficient inlet pressure. ▷ Provide an appropriate monitoring system.



	<p>⚠ DANGER</p> <p>Risk of potentially explosive atmosphere by mixing of incompatible fluids in the auxiliary piping Risk of burns! Explosion hazard!</p> <ul style="list-style-type: none"> ▷ Make sure that the barrier fluid or quench liquid are compatible with the fluid handled.
	<p>⚠ DANGER</p> <p>Shaft seal failure caused by insufficient lubrication Hot or toxic fluid could escape! Damage to the pump!</p> <ul style="list-style-type: none"> ▷ Before starting up the pump set, vent the pump and suction line and prime both with the fluid to be handled.
	<p>CAUTION</p> <p>Increased wear due to dry running Damage to the pump set!</p> <ul style="list-style-type: none"> ▷ Never operate the pump set without liquid fill. ▷ Never close the shut-off element in the suction line and/or supply line during pump operation.
<ol style="list-style-type: none"> 1. Vent the pump and suction line and prime both with the fluid to be handled. Connection 6D can be used for venting (see drawing of auxiliary connections). 2. Fully open the shut-off element in the suction line. 3. Fully open all auxiliary feed lines (barrier fluid, flushing liquid, etc.), if any. 4. Open the shut-off element, if any, in the vacuum balance line and close the vacuum-tight shut-off element, if any. (⇒ Section 5.4.3, Page 29) 	
	<p>NOTE</p> <p>For design-inherent reasons some unfilled volume in the hydraulic system cannot be excluded after the pump has been primed for commissioning/start-up. However, once the motor is started up the pumping effect will immediately fill this volume with the fluid handled.</p>

6.1.4 Final check

1. Remove the coupling guard and its footboard, if any.
2. Check the coupling alignment; re-align the coupling, if required. (⇒ Section 5.6, Page 31)
3. Check proper functioning of coupling/shaft.
Check that coupling/shaft can be easily rotated by hand.
4. Fit the coupling guard and its footboard, if any.
5. Check the distance between coupling and coupling guard.
The coupling guard must not touch the coupling.

6.1.5 Start-up

 	<p>⚠ DANGER</p>
<p>Non-compliance with the permissible pressure and temperature limits if the pump is operated with the suction and/or discharge line closed.</p> <p>Explosion hazard! Hot or toxic fluids escaping!</p> <ul style="list-style-type: none"> ▷ Never operate the pump with the shut-off elements in the suction line and/or discharge line closed. ▷ Only start up the pump set with the discharge-side shut-off element slightly or fully open. 	

 	<p>⚠ DANGER</p>
<p>Excessive temperatures due to dry running or excessive gas content in the fluid handled</p> <p>Explosion hazard! Damage to the pump set!</p> <ul style="list-style-type: none"> ▷ Never operate the pump set without liquid fill. ▷ Prime the pump as per operating instructions. (⇒ Section 6.1.3, Page 38) ▷ Always operate the pump within the permissible operating range. 	

	<p>CAUTION</p>
<p>Abnormal noises, vibrations, temperatures or leakage</p> <p>Damage to the pump!</p> <ul style="list-style-type: none"> ▷ Switch off the pump (set) immediately. ▷ Eliminate the causes before returning the pump set to service. 	

- ✓ The system piping has been cleaned.
- ✓ The pump, suction line and inlet tank, if any, have been vented and primed with the fluid to be handled.
- ✓ The lines for priming and venting have been closed.

	<p>CAUTION</p>
<p>Start-up against open discharge line</p> <p>Motor overload!</p> <ul style="list-style-type: none"> ▷ Make sure the motor has sufficient power reserves. ▷ Use a soft starter. ▷ Use speed control. 	

1. Fully open the shut-off element in the suction head/suction lift line.
2. Close or slightly open the shut-off element in the discharge line.
3. Start up the motor.

4. Immediately after the pump has reached full rotational speed, slowly open the shut-off element in the discharge line and adjust it to comply with the duty point.

	CAUTION
	<p>Misalignment of pump and coupling Damage to pump, motor and coupling!</p> <ul style="list-style-type: none"> ▷ When the operating temperature has been reached, switch off the pump set and check the coupling alignment.

5. Check the coupling alignment and re-align the coupling, if required.

6.1.6 Checking the shaft seal

Mechanical seal The mechanical seal only leaks slightly or invisibly (as vapour) during operation. Mechanical seals are maintenance-free.

Gland packing The gland packing must drip slightly during operation.

Pure graphite packing If a pure graphite packing is used, there must always be some leakage.

Table 13: Leakage rate of the pure graphite packing

Quantity	Values
Minimum	10 cm ³ /min
Maximum	20 cm ³ /min

Adjusting the leakage

- Prior to commissioning**
1. Only lightly tighten the nuts of the gland follower by hand.
 2. Use a feeler gauge to verify that the gland follower is mounted centred and at a right angle to the shaft.
- ⇒ The gland must leak after the pump has been primed.

After five minutes of operation

	! WARNING
	<p>Unprotected rotating parts Risk of personal injury!</p> <ul style="list-style-type: none"> ▷ Do not touch rotating parts. ▷ When the pump is running, perform any work with utmost caution.

The leakage can be reduced.

1. Tighten the nuts on the gland follower by 1/6 turn.
2. Monitor the leakage for another five minutes.

Excessive leakage:

Repeat steps 1 and 2 until the minimum value has been reached.

Not enough leakage:

Slightly loosen the nuts at the gland follower.

No leakage:

Immediately switch off pump set!

Loosen the gland follower and repeat commissioning.

Checking the leakage

After the leakage has been adjusted, monitor the leakage for about two hours at maximum fluid temperature.

Check that enough leakage occurs at the gland packing at minimum fluid pressure.

6.1.7 Shutdown

	CAUTION
	<p>Heat build-up inside the pump Damage to the shaft seal!</p> <ul style="list-style-type: none"> ▷ Depending on the type of installation, the pump set requires sufficient after-run time – with the heat source switched off – until the fluid handled has cooled down.

	CAUTION
	<p>Backflow of fluid handled is not permitted Motor or winding damage! Mechanical seal damage!</p> <ul style="list-style-type: none"> ▷ Close the shut-off elements.

- ✓ The shut-off element in the suction line is and remains open.
- 1. Close the shut-off element in the discharge line.
- 2. Switch off the motor and make sure the pump set runs down smoothly to a standstill.

	NOTE
	<p>If the discharge line is equipped with a non-return or check valve, the shut-off element may remain open provided that the system conditions and system regulations are considered and observed.</p>

For prolonged shutdown periods:

- 1. Close the shut-off element in the suction line.
- 2. Close any auxiliary lines.
If the fluid to be handled is fed in under vacuum, also supply the shaft seal with barrier fluid during standstill.

	CAUTION
	<p>Risk of freezing during prolonged pump shutdown periods Damage to the pump!</p> <ul style="list-style-type: none"> ▷ Drain the pump and the cooling/heating chambers (if any) or otherwise protect them against freezing.

6.2 Operating limits

	⚠ DANGER
	<p>Non-compliance with operating limits for pressure, temperature, fluid handled and speed Explosion hazard! Hot or toxic fluid could escape!</p> <ul style="list-style-type: none"> ▷ Comply with the operating data indicated in the data sheet. ▷ Never use the pump for handling fluids it is not designed for. ▷ Avoid prolonged operation against a closed shut-off element. ▷ Never operate the pump at temperatures, pressures or rotational speeds exceeding those specified in the data sheet or on the name plate unless the written consent of the manufacturer has been obtained.

	DANGER
	<p>Formation of a potentially explosive atmosphere inside the pump Explosion hazard!</p> <ul style="list-style-type: none"> ▷ When draining tanks take suitable measures to prevent dry running of the pump (e.g. fill level monitoring).

6.2.1 Ambient temperature

	CAUTION
	<p>Operation outside the permissible ambient temperature Damage to the pump (set)!</p> <ul style="list-style-type: none"> ▷ Observe the specified limits for permissible ambient temperatures.

Observe the following parameters and values during operation:

Table 14: Permissible ambient temperatures

Permissible ambient temperature	Value
Maximum	40 °C
Minimum	See data sheet.

6.2.2 Frequency of starts

	DANGER
	<p>Excessive surface temperature of the motor Explosion hazard! Damage to the motor!</p> <ul style="list-style-type: none"> ▷ In case of explosion-proof motors, observe the frequency of starts specified in the manufacturer's product literature.

The frequency of starts is usually determined by the maximum temperature increase of the motor. This largely depends on the power reserves of the motor in steady-state operation and on the starting conditions (DOL, star-delta, moments of inertia, etc). If the starts are evenly spaced over the period indicated, the following limits serve as orientation for start-up with the discharge-side gate valve slightly open:

Table 15: Frequency of starts

Impeller material	Maximum frequency of starts
	[Start-ups/hour]
G (JL1040/ A48CL35B)	15
B (CC480K-GS/B30 C90700)	6
C (1.4408/ A743 GR CF8M)	

	CAUTION
	<p>Re-starting while motor is still running down Damage to the pump (set)!</p> <ul style="list-style-type: none"> ▷ Do not re-start the pump set before the pump rotor has come to a standstill.

6.2.3 Fluid handled

6.2.3.1 Flow rate

Table 16: Flow rate

Temperature range (t)	Minimum flow rate	Maximum flow rate
-30 to +80 °C	≈ 15 % of $Q_{opt}^{5)}$	See hydraulic characteristic curves.
> 80 to +140 °C	≈ 25 % of $Q_{opt}^{5)}$	

The calculation formula below can be used to check if an additional heat build-up could lead to a dangerous temperature increase at the pump surface.

$$T_o = T_f + \Delta \vartheta$$

$$\Delta \vartheta = \frac{g \times H}{c \times \eta} \times (1 - \eta)$$

Table 17: Key

Symbol	Description	Unit
c	Specific heat capacity	J/kg K
g	Gravitational constant	m/s ²
H	Pump discharge head	m
T _f	Fluid temperature	°C
T _o	Temperature at the casing surface	°C
η	Pump efficiency at duty point	-
Δϑ	Temperature difference	K

6.2.3.2 Density of the fluid handled

The pump input power changes in proportion to the density of the fluid handled.

	CAUTION
	<p>Impermissibly high density of the fluid handled Motor overload!</p> <ul style="list-style-type: none"> ▷ Observe the information about fluid density in the data sheet. ▷ Make sure the motor has sufficient power reserves.

6.2.3.3 Abrasive fluids

The fluid handled may contain abrasive particles up to a maximum content of 5 g/dm³ and a maximum particle size of 0.5 mm. When the pump handles fluids containing abrasive substances, increased wear of the hydraulic system and the shaft seal are to be expected. In this case, reduce the commonly recommended inspection intervals.

6.3 Shutdown/storage/preservation

6.3.1 Measures to be taken for shutdown

The pump (set) remains installed

- ✓ Sufficient fluid is supplied for the operation check run of the pump.
 1. For prolonged shutdown periods, start up the pump (set) regularly between once a month and once every three months for approximately five minutes.
 - ⇒ This will prevent the formation of deposits within the pump and the pump intake area.

5) Best efficiency point

The pump (set) is removed from the pipe and stored

- ✓ The pump has been properly drained. (⇒ Section 7.3, Page 53)
- ✓ The safety instructions for dismantling the pump have been observed. (⇒ Section 7.4.1, Page 53)
 1. Spray-coat the inside wall of the pump casing and, in particular, the impeller clearance areas with a preservative.
 2. Spray the preservative through the suction nozzle and discharge nozzle. It is advisable to then close the pump nozzles (e.g. with plastic caps).
 3. Oil or grease all exposed machined parts and surfaces of the pump (with silicone-free oil or grease, food-approved if required) to protect them against corrosion.
Observe the additional instructions on preservation. (⇒ Section 3.3, Page 14)

If the pump set is to be stored temporarily, only preserve the wetted components made of low-alloy materials. Commercially available preservatives can be used for this purpose. Observe the manufacturer's instructions for application/removal.

6.4 Returning to service











For returning the equipment to service observe the sections on commissioning/start-up and the operating limits. (⇒ Section 6.1, Page 37) (⇒ Section 6.2, Page 42)

In addition, carry out all servicing/maintenance operations before returning the pump (set) to service. (⇒ Section 7, Page 46)

	<p>! WARNING</p> <p>Failure to re-install or re-activate protective devices Risk of injury from moving parts or escaping fluid!</p> <ul style="list-style-type: none"> ▸ As soon as the work is completed, re-install and re-activate any safety-relevant devices and protective devices.
	<p>NOTE</p> <p>If the pump has been out of service for more than one year, replace all elastomer seals.</p>

7 Servicing/Maintenance

7.1 Safety regulations

	<p style="background-color: #e67e22; color: white; padding: 5px;"> DANGER</p> <p>Improper cleaning of coated pump surfaces Explosion hazard by electrostatic discharge!</p> <ul style="list-style-type: none"> ▷ When cleaning coated pump surfaces in atmospheres of Explosion group IIC, use suitable anti-static equipment.
	<p style="background-color: #e67e22; color: white; padding: 5px;"> DANGER</p> <p>Sparks produced during servicing work Explosion hazard!</p> <ul style="list-style-type: none"> ▷ Observe the safety regulations in force at the place of installation! ▷ Always perform maintenance work at an explosion-proof pump (set) outside of potentially explosive atmospheres.
 	<p style="background-color: #e67e22; color: white; padding: 5px;"> DANGER</p> <p>Improperly serviced pump set Explosion hazard! Damage to the pump set!</p> <ul style="list-style-type: none"> ▷ Service the pump set regularly. ▷ Prepare a maintenance schedule with special emphasis on lubricants, shaft seal and coupling.
<p>The operator ensures that maintenance, inspection and installation is performed by authorised, qualified specialist personnel who are thoroughly familiar with the manual.</p>	
	<p style="background-color: #f1c40f; padding: 5px;"> WARNING</p> <p>Unintentional starting of the pump set Risk of injury by moving components and shock currents!</p> <ul style="list-style-type: none"> ▷ Ensure that the pump set cannot be started unintentionally. ▷ Always make sure the electrical connections are disconnected before carrying out work on the pump set.
	<p style="background-color: #f1c40f; padding: 5px;"> WARNING</p> <p>Fluids handled, consumables and supplies which are hot and/or pose a health hazard Risk of injury!</p> <ul style="list-style-type: none"> ▷ Observe all relevant laws. ▷ When draining the fluid take appropriate measures to protect persons and the environment. ▷ Decontaminate pumps which handle fluids posing a health hazard.

	<p>⚠ WARNING</p>
	<p>Insufficient stability Risk of crushing hands and feet!</p> <ul style="list-style-type: none"> ▷ During assembly/dismantling, secure the pump (set)/pump parts to prevent tilting or tipping over.

A regular maintenance schedule will help avoid expensive repairs and contribute to trouble-free, reliable operation of the pump, pump set and pump parts with a minimum of servicing/maintenance expenditure and work.

	<p>NOTE</p>
	<p>All maintenance work, service work and installation work can be carried out by KSB Service or authorised workshops. For contact details please refer to the enclosed "Addresses" booklet or visit "www.ksb.com/contact" on the Internet.</p>

Never use force when dismantling and reassembling the pump set.



7.2 Servicing/Inspection

7.2.1 Supervision of operation

	<p>⚠ DANGER</p>
	<p>Risk of potentially explosive atmosphere inside the pump Explosion hazard!</p> <ul style="list-style-type: none"> ▷ The pump internals in contact with the fluid to be handled, including the seal chamber and auxiliary systems must be filled with the fluid to be handled at all times. ▷ Provide sufficient inlet pressure. ▷ Provide an appropriate monitoring system.

 	<p>⚠ DANGER</p>
	<p>Incorrectly serviced shaft seal Explosion hazard! Hot, toxic fluid escaping! Damage to the pump set! Risk of burns! Fire hazard!</p> <ul style="list-style-type: none"> ▷ Regularly service the shaft seal.

 	<p>⚠ DANGER</p>
	<p>Excessive temperatures as a result of bearings running hot or defective bearing seals Explosion hazard! Fire hazard! Damage to the pump set! Risk of burns!</p> <ul style="list-style-type: none"> ▷ Regularly check the lubricant level. ▷ Regularly check the rolling element bearings for running noises.

	<p>⚠ DANGER</p> <p>Incorrectly serviced barrier fluid system Explosion hazard! Fire hazard! Damage to the pump set! Hot and/or toxic fluids escaping!</p> <ul style="list-style-type: none"> ▷ Regularly service the barrier fluid system. ▷ Monitor the barrier fluid pressure.
	<p>CAUTION</p> <p>Increased wear due to dry running Damage to the pump set!</p> <ul style="list-style-type: none"> ▷ Never operate the pump set without liquid fill. ▷ Never close the shut-off element in the suction line and/or supply line during pump operation.
	<p>CAUTION</p> <p>Impermissibly high temperature of fluid handled Damage to the pump!</p> <ul style="list-style-type: none"> ▷ Prolonged operation against a closed shut-off element is not permitted (heating up of the fluid). ▷ Observe the temperature limits in the data sheet and in the section on operating limits. (⇒ Section 6.2, Page 42)

While the pump is in operation, observe and check the following:

- The pump must run quietly and free from vibrations at all times.
- In case of oil lubrication, ensure the oil level is correct. (⇒ Section 6.1.2, Page 37)
- Check the shaft seal. (⇒ Section 6.1.6, Page 41)
- Check the static sealing elements for leakage.
- Check the rolling element bearings for running noises.
 Vibrations, noise and an increase in current input occurring during unchanged operating conditions indicate wear.
- Monitor the correct functioning of any auxiliary connections.
- Monitor the stand-by pump.
 To make sure that stand-by pumps are ready for operation, start them up once a week.
- Monitor the bearing temperature.
 The bearing temperature must not exceed 90 °C (measured on the outside of the bearing bracket).

	<p>CAUTION</p> <p>Operation outside the permissible bearing temperature Damage to the pump!</p> <ul style="list-style-type: none"> ▷ The bearing temperature of the pump (set) must never exceed 90 °C (measured on the outside of the bearing bracket).
---	--

	NOTE
	<p>After commissioning, increased temperatures may occur at grease-lubricated rolling element bearings due to the running-in process. The final bearing temperature is only reached after a certain period of operation (up to 48 hours depending on the conditions).</p>

7.2.2 Inspection work

 	⚠ DANGER
	<p>Excessive temperatures caused by friction, impact or frictional sparks Explosion hazard! Fire hazard! Damage to the pump set!</p> <ul style="list-style-type: none"> ▶ Regularly check the coupling guard, plastic components and other guards of rotating parts for deformation and sufficient distance from rotating parts.

	⚠ DANGER
	<p>Static charging due to insufficient potential equalisation Explosion hazard!</p> <ul style="list-style-type: none"> ▶ Make sure that the connection between pump and baseplate is electrically conductive.

7.2.2.1 Checking the coupling

Check the flexible elements of the coupling. Replace the relevant parts in due time if there is any sign of wear and check the alignment.

7.2.2.2 Checking the clearances

To check the clearances, remove the back pull-out unit.
If the clearance is larger than permitted (see the following table), fit a new casing wear ring 502.1 and/or 502.2.
The clearances specified refer to the impeller diameter.



Table 18: Clearances between impeller and casing / between impeller and casing cover

Impeller material	Permissible clearance	
	New	Maximum
G (JL1040/ A48CL35B) B (CC480K-GS/B30 C90700) I (LTB 2)	0,3 mm	0,9 mm
C (1.4408/ A743 GR CF8M)	0,5 mm	1,5 mm



7.2.2.3 Cleaning filters

	CAUTION
	<p>Insufficient inlet pressure due to clogged filter in the suction line Damage to the pump!</p> <ul style="list-style-type: none"> ▶ Monitor contamination of filter with suitable means (e.g. differential pressure gauge). ▶ Clean filter at appropriate intervals.

7.2.2.4 Checking the bearing seals

 	 DANGER
	<p>Excessive temperatures caused by mechanical contact Risk of explosion! Damage to the pump set!</p> <p>▸ Check correct seating of axial seal rings mounted on the shaft. Only gentle contact of the sealing lip shall be established.</p>

7.2.3 Lubrication and lubricant change of rolling element bearings

 	 DANGER
	<p>Excessive temperatures as a result of bearings running hot or defective bearing seals Explosion hazard! Fire hazard! Damage to the pump set!</p> <p>▸ Regularly check the condition of the lubricant.</p>

7.2.3.1 Oil lubrication

The rolling element bearings are usually lubricated with mineral oil.

7.2.3.1.1 Intervals

Table 19: Oil change intervals

Oil change	Interval
Initial oil change	after 300 operating hours
Further oil changes	every 3000 operating hours ⁶⁾

7.2.3.1.2 Oil quality

Table 20: Oil quality⁷⁾

Description	Symbol to DIN 51502	Properties	
		Lubricating oil C 46 CL 46 CLP 46	□
Flash point (to Cleveland)	+175 °C		
Solidification point (pour point)	-15 °C		
Application temperature ⁸⁾	Higher than permissible bearing temperature		

6) At least once a year

7) To DIN 51517

8) For ambient temperatures below -10 °C use a different suitable type of lubricating oil. Contact the manufacturer.

7.2.3.1.3 Oil quantity

Table 21: Oil quantity per oil-lubricated DIN 625 radial ball bearing

Shaft unit ⁹⁾	Code	Oil quantity per bearing bracket
		[L]
25	6305 C3	0,20
35	6307 C3	0,35
50	6310 C3	0,40
55	6311 C3	0,65
60	6312 C3	0,40

7.2.3.1.4 Changing the oil

	WARNING
	<p>Lubricants posing a health hazard and/or hot lubricants Hazard to persons and the environment!</p> <ul style="list-style-type: none"> ▷ When draining the lubricant take appropriate measures to protect persons and the environment. ▷ Wear safety clothing and a protective mask if required. ▷ Collect and dispose of any lubricants. ▷ Observe all legal regulations on the disposal of fluids posing a health hazard.

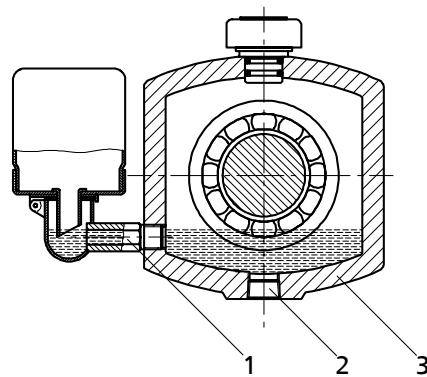

Fig. 17: Bearing bracket with constant level oiler

1	Constant level oiler	2	Screw plug
3	Bearing bracket		

- ✓ A suitable container for the used oil is on hand.
 1. Place the container underneath the screw plug.
 2. Undo the screw plug (2) at the bearing bracket (3) and drain the oil.
 3. Once the bearing bracket (3) has been drained, re-insert and re-tighten the screw plug (2).
 4. Re-fill with oil. (⇒ Section 6.1.2, Page 37)

7.2.3.2 Grease lubrication

The bearings are supplied packed with high-quality lithium-soap grease.

9) Shaft unit see data sheet.

7.2.3.2.1 Intervals

Under normal conditions the grease-lubricated bearings will run for 15,000 operating hours or 2 years. Under unfavourable operating conditions (e.g. high room temperature, high atmospheric humidity, dust-laden air, aggressive industrial atmosphere etc.), check the bearings earlier and clean and relubricate them if required.

7.2.3.2.2 Grease quality

Optimum grease properties for rolling element bearings

Table 22: Grease quality to DIN 51825

Soap basis	NLGI grade	Worked penetration at 25° C in mm/10	Drop point
Lithium	2 to 3	220-295	≥ 175 °C

- Free of resin and acid
- Not liable to crumble
- Rust-preventive characteristics

If required, the bearings may be lubricated with greases of other soap bases. Make sure to remove any old grease and rinse the bearings thoroughly.

7.2.3.2.3 Grease quantity

Table 23: Grease quantity per grease-lubricated DIN 625 radial ball bearing

Shaft unit ¹⁰⁾	Code	Grease quantity per bearing
		[g]
25	6305 2Z C3	5
35	6307 2Z C3	10
50	6310 2Z C3	12
55	6311 2Z C3	15
60	6312 2Z C3	20

7.2.3.2.4 Changing the grease

	CAUTION
	<p>Mixing greases of differing soap bases Changed lubricating qualities!</p> <ul style="list-style-type: none"> ▷ Thoroughly clean the bearings. ▷ Adjust the re-lubrication intervals to the grease used.

✓ The pump has been dismantled for changing the grease.

1. Remove the outer cover plate of each bearing with a suitable tool. Dispose of the cover plates.
2. Only half-fill the bearing cavities with grease.

Continue using the bearings without the outer cover plates (variant Z C3).

10) Shaft unit see data sheet.

7.3 Drainage/cleaning

	WARNING
	<p>Fluids handled, consumables and supplies which are hot and/or pose a health hazard</p> <p>Hazard to persons and the environment!</p> <ul style="list-style-type: none"> ▸ Collect and properly dispose of flushing fluid and any fluid residues. ▸ Wear safety clothing and a protective mask if required. ▸ Observe all legal regulations on the disposal of fluids posing a health hazard.

1. Use connection 6B to drain the fluid handled (see drawing of auxiliary connections).
2. Always flush the system if it has been used for handling noxious, explosive, hot or other hazardous fluids.
Always flush and clean the pump before transporting it to the workshop.
Provide a certificate of decontamination for the pump. (⇒ Section 11, Page 78)

7.4 Dismantling the pump set

7.4.1 General information/Safety regulations



	DANGER
	<p>Insufficient preparation of work on the pump (set)</p> <p>Risk of injury!</p> <ul style="list-style-type: none"> ▸ Properly shut down the pump set. (⇒ Section 6.1.7, Page 42) ▸ Close the shut-off elements in the suction line and discharge line. ▸ Drain the pump and release the pump pressure. (⇒ Section 7.3, Page 53) ▸ Shut off any auxiliary feed lines. ▸ Allow the pump set to cool down to ambient temperature.
	WARNING
	<p>Unqualified personnel performing work on the pump (set)</p> <p>Risk of injury!</p> <ul style="list-style-type: none"> ▸ Always have repair work and maintenance work performed by specially trained, qualified personnel.
	WARNING
	<p>Hot surface</p> <p>Risk of injury!</p> <ul style="list-style-type: none"> ▸ Allow the pump set to cool down to ambient temperature.
	WARNING
	<p>Improper lifting/moving of heavy assemblies or components</p> <p>Personal injury and damage to property!</p> <ul style="list-style-type: none"> ▸ Use suitable transport devices, lifting equipment and lifting tackle to move heavy assemblies or components.

Always observe the safety instructions and information. (⇒ Section 7.1, Page 46)

For any work on the motor, observe the instructions of the relevant motor manufacturer.

For dismantling and reassembly observe the exploded views and the general assembly drawing. (⇒ Section 9.1, Page 68)



In case of damage you can always contact KSB Service.

	NOTE
	All maintenance work, service work and installation work can be carried out by KSB Service or authorised workshops. For contact details please refer to the enclosed "Addresses" booklet or visit " www.ksb.com/contact " on the Internet.
	NOTE
	After a prolonged period of operation the individual components may be hard to pull off the shaft. If this is the case, use a brand name penetrating agent and/or - if possible - an appropriate puller.

7.4.2 Preparing the pump set

1. Interrupt the power supply and secure the pump against unintentional start-up.
2. Disconnect and remove all auxiliary pipework.
3. Remove the coupling guard.
4. Remove the coupling spacer, if any.
5. Drain the oil fill of oil-lubricated bearings. (⇒ Section 7.2.3.1.4, Page 51)

7.4.3 Removing the motor

	NOTE
	On pump sets with spacer-type couplings, the back pull-out unit can be removed while the motor remains bolted to the baseplate.
	WARNING
	Motor tilting Risk of crushing hands and feet! ▷ Suspend or support the motor to prevent it from tilting.

1. Disconnect the motor from the power supply.
2. Unbolt the motor from the baseplate.
3. Shift the motor to separate it from the pump.

7.4.4 Removing the back pull-out unit

- ✓ The notes and steps stated in (⇒ Section 7.4.1, Page 53) to (⇒ Section 7.4.3, Page 54) have been observed/carried out.
- ✓ On pump sets without spacer-type coupling, the motor has been removed.

	WARNING
	Back pull-out unit tilting Risk of crushing hands and feet! ▷ Suspend or support the bearing bracket at the pump end.

1. If required, suspend or support bearing bracket 330 to prevent it from tipping over.
2. Unbolt support foot 183 from the baseplate.
3. Undo nut 920.01 at the volute casing.

4. Use forcing screws 901.30 (for bolted casing covers) or 901.31 (for clamped casing covers) to remove the back pull-out unit from its seat in the volute casing. Pull the back pull-out unit completely out of the volute casing.
5. Remove and dispose of gasket 400.10.
6. Place the back pull-out unit on a clean and level surface.

7.4.5 Removing the impeller

- ✓ The notes and steps stated in (⇒ Section 7.4.1, Page 53) to (⇒ Section 7.4.4, Page 54) have been observed/carried out.
- ✓ The back pull-out unit has been placed in a clean and level assembly area.
 1. Undo impeller nut 920.95 (right-hand thread).
 2. Remove impeller 230 with an impeller removal tool.
 3. Place impeller 230 on a clean and level surface.
 4. Remove keys 940.01 and 940.09 (if any) from shaft 210.

7.4.6 Removing the shaft seal

7.4.6.1 Removing a single mechanical seal

- ✓ The notes and steps stated in (⇒ Section 7.4.1, Page 53) to (⇒ Section 7.4.5, Page 55) have been observed/carried out.
- ✓ The back pull-out unit has been placed in a clean and level assembly area.
 1. Remove the rotating assembly of the mechanical seal (primary ring) from shaft sleeve 523.
 2. Undo nuts 920.15 (if any) at casing cover 161.
 3. **For models with clamped casing cover:** Undo transport locks 901.98 and remove cover plates 81-92.01 and 81-92.02 with transport locks 901.98 and lock washers 554.98. Remove casing cover 161 from bearing bracket 330.
For models with bolted casing cover: Use forcing screws 901.31 to remove casing cover 161 from bearing bracket 330.
 4. Remove the stationary assembly of the mechanical seal (mating ring) from casing cover 161.
 5. Pull shaft sleeve 523 off shaft 210.
 6. Remove and dispose of gasket 400.75.

7.4.6.2 Removing a double mechanical seal

See supplementary operating manual.

7.4.6.3 Dismantling the gland packing

- ✓ The notes and steps stated in (⇒ Section 7.4.1, Page 53) to (⇒ Section 7.4.5, Page 55) have been observed/carried out.
- ✓ The back pull-out unit has been placed in a clean and level assembly area.
 1. Undo nuts 920.02 at the gland follower and loosen gland follower 452.
 2. Undo nuts 920.15 (if any) at casing cover 161.
 3. **For models with a clamped casing cover:** Undo transport locks 901.98 and remove cover plates 81-92.01 and 81-92.02 with transport locks 901.98 and lock washers 554.98. Remove casing cover 161 from bearing bracket 330.
For models with a bolted casing cover: Use forcing screws 901.31 to remove casing cover 161 from bearing bracket 330.
 4. Remove gland follower 452 from casing cover 161 and remove the packing.
 5. Remove stuffing box ring 454.
 6. Remove packing rings 461 and lantern ring 458, if any.

7. Pull shaft protecting sleeve 524 off shaft 210.
8. Remove and dispose of gasket 400.75.

7.4.7 Dismantling the bearings

Oil lubrication

- ✓ The notes and steps stated in (⇒ Section 7.4.1, Page 53) to (⇒ Section 7.4.6, Page 55) have been observed/carried out.
- ✓ The bearing bracket has been placed in a clean and level assembly area.
 1. Undo the grub screw in the coupling hub.
 2. Pull the coupling hub off pump shaft 210 with a puller.
 3. Remove key 940.02.
 4. Remove thrower 507.01.
 5. Remove pump-end bearing cover 360.01 and drive-end bearing cover 360.02.
 6. Remove hexagon head bolts 901.01 and 901.02 as well as gaskets 400.01 and 400.02.
 7. Press shaft 210 out of the shaft seat.
 8. Remove radial ball bearings 321.01 and 321.02, and place them on a clean and level surface.
 9. Dispose of gaskets 400.01 and 400.02.

Grease lubrication for shaft units 25, 35, 55 (standard bearing assembly)



- ✓ The notes and steps stated in (⇒ Section 7.4.1, Page 53) to (⇒ Section 7.4.6, Page 55) have been observed/carried out.
- ✓ The bearing bracket has been placed in a clean and level assembly area.
 1. Undo the grub screw in the coupling hub.
 2. Pull the coupling hub off pump shaft 210 with a puller.
 3. Remove key 940.02.
 4. Remove axial seal rings 411.01 and 411.02.
 5. Remove pump-end bearing cover 360.01 and drive-end bearing cover 360.02.
 6. Remove circlips 932.01 and 932.02.
 7. Press shaft 210 out of the bearing seats.
 8. Remove radial ball bearings 321.01 and 321.02, and place them on a clean and level surface.

Grease lubrication for shaft units 50 and 60 (reinforced bearing assembly)

- ✓ The notes and steps stated in (⇒ Section 7.4.1, Page 53) to (⇒ Section 7.4.6, Page 55) have been observed/carried out.
- ✓ The bearing bracket has been placed in a clean and level assembly area.
 1. Undo the grub screw in the coupling hub.
 2. Pull the coupling hub off pump shaft 210 with a puller.
 3. Remove key 940.02.
 4. Remove thrower 507.01.
 5. Remove pump-end bearing cover 360.01 and drive-end bearing cover 360.02.
 6. Remove hexagon head bolts 901.01 and 901.02 as well as gaskets 400.01 and 400.02.
 7. Press shaft 210 out of the shaft seat.
 8. Remove radial ball bearings 321.01 and 321.02, and place them on a clean and level surface.

7.5 Reassembling the pump set

7.5.1 General information/Safety regulations

	<p>⚠ WARNING</p> <p>Improper lifting/moving of heavy assemblies or components Personal injury and damage to property!</p> <ul style="list-style-type: none"> ▷ Use suitable transport devices, lifting equipment and lifting tackle to move heavy assemblies or components.
	<p>CAUTION</p> <p>Improper reassembly Damage to the pump!</p> <ul style="list-style-type: none"> ▷ Reassemble the pump (set) in accordance with the general rules of sound engineering practice. ▷ Use original spare parts only.

Sequence Always reassemble the pump in accordance with the corresponding general assembly drawing or exploded view.

Sealing elements Check O-rings for any damage and replace by new O-rings if required.
 Always use new gaskets, making sure that they have the same thickness as the old ones.

Always fit gaskets of asbestos-free materials or graphite without using lubricants (e.g. copper grease, graphite paste).

Assembly adhesives Avoid the use of assembly adhesives if possible.

Should an assembly adhesive be required after all, use a commercially available contact adhesive (e.g. Pattex) or sealant (e.g. HYLOMAR or Eppele 33).

Only apply adhesive at selected points and in thin layers.

Never use quick-setting adhesives (cyanoacrylate adhesives).

Coat the locating surfaces of the individual components with graphite or similar before reassembly.

Prior to reassembly, screw back any forcing screws and adjusting screws.

Tightening torques For reassembly, tighten all screws and bolts as specified in this manual.
 (⇒ Section 7.6, Page 63)

7.5.2 Fitting the bearings

Oil lubrication

- ✓ The individual parts have been placed in a clean and level assembly area.
- ✓ All dismantled parts have been cleaned and checked for wear.
- ✓ Any damaged or worn parts have been replaced by original spare parts.
- ✓ The sealing surfaces have been cleaned.

1. Press radial ball bearings 321.01 and 321.02 onto shaft 210.
2. Slide the pre-assembled shaft into bearing bracket 330.
3. Insert new gaskets 400.01 and 400.02.
4. Fasten bearing covers 360.01 and 360.02 with hexagon head bolts 901.01 and 901.02. Watch lip seals 421.01 and 421.02.
5. Fit thrower 507.
6. Insert key 940.02.
7. Pull the coupling half onto the drive-end shaft stub.
8. Secure the coupling hub with a grub screw.

Grease lubrication for shaft units 25, 35, 55 (standard bearing assembly)

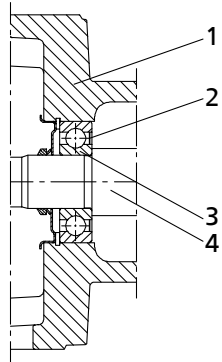

Fig. 18: Installing the radial ball bearing

1	Bearing bracket	2	Shield
3	Radial ball bearing	4	Shaft

- ✓ The individual parts have been placed in a clean and level assembly area.
- ✓ All dismantled parts have been cleaned and checked for wear.
- ✓ Any damaged or worn parts have been replaced by original spare parts.
- ✓ The sealing surfaces have been cleaned.

1. Press radial ball bearings 321.01 and 321.02 onto shaft 210.
Make sure the bearing side with the shield rests against the shaft shoulder (see illustration: Installing the radial ball bearings).
2. Slide the pre-assembled shaft into bearing bracket 330.
3. Fit circlips 932.01 and 932.02.
4. Fit bearing covers 360.01 and 360.02.
5. Fit axial seal rings 411.01 and 411.02.
6. Insert key 940.02.
7. Pull the coupling half onto the drive-end shaft stub.
8. Secure the coupling hub with a grub screw.

Grease lubrication for shaft units 50 and 60 (reinforced bearing assembly)

- ✓ The individual parts have been placed in a clean and level assembly area.
- ✓ All dismantled parts have been cleaned and checked for wear.
- ✓ Any damaged or worn parts have been replaced by original spare parts.
- ✓ The sealing surfaces have been cleaned.

1. Press radial ball bearings 321.01 and 321.02 onto shaft 210.
Make sure the bearing side with the cover plate rests against the shaft shoulder (see illustration: Installing the radial ball bearings).
2. Slide the pre-assembled shaft into bearing bracket 330.
3. Fill lip seals 421.01 and 421.02 with bearing grease.
4. Fit circlips 932.01 and 932.02.
5. Fasten bearing covers 360.01 and 360.02 with hexagon head bolts 901.01 and 901.02. Watch lip seals 421.01 and 421.02.
6. Fit thrower 507.
7. Insert key 940.02.
8. Pull the coupling half onto the drive-end shaft stub.
9. Secure the coupling hub with a grub screw.

7.5.3 Fitting the shaft seal

7.5.3.1 Installing a single mechanical seal

Installing the mechanical seal

The following rules must be observed when installing the mechanical seal:

- Work cleanly and accurately.
- Only remove the protective wrapping of the contact faces immediately before installation takes place.
- Prevent any damage to the sealing surfaces or O-rings.
- ✓ The notes and steps stated in (⇒ Section 7.5.1, Page 57) to (⇒ Section 7.5.2, Page 57) have been observed/carried out.
- ✓ The bearing assembly as well as the individual parts have been placed in a clean and level assembly area.
- ✓ All dismantled parts have been cleaned and checked for wear.
- ✓ Any damaged or worn parts have been replaced by original spare parts.
- ✓ The sealing surfaces have been cleaned.
 1. Clean shaft sleeve 523, and touch up any score marks or scratches with a polishing cloth, if necessary.
If score marks or scratches are still visible, fit new shaft sleeve 523.
 2. Slide shaft sleeve 523 with new gasket 400.75 onto shaft 210.
 3. Clean the mating ring location in casing cover 161.

	CAUTION
	<p>Elastomers in contact with oil/grease Shaft seal failure!</p> <ul style="list-style-type: none"> ▷ Use water as assembly lubricant. ▷ Never use oil or grease as assembly lubricant.

4. Carefully insert the mating ring.
Make sure to apply pressure evenly.
5. On models with a bolted casing cover, loosen but do not remove forcing screws 901.31.
6. Place casing cover 161 into the locating fit of bearing bracket 330.
7. On models with a clamped casing cover, fasten cover plates 81-92.01 and 81-92.02 with transport locks 901.98 and lock washers 554.98. The casing cover is now fastened to the bearing bracket.
8. Fit and tighten nuts 920.15, if any.

	NOTE
	<p>To reduce friction forces when assembling the seal, wet the shaft sleeve and the location of the stationary ring with water.</p>

9. Fit the rotating assembly of the mechanical seal (primary ring) on shaft sleeve 523.

Observe the following installation dimension b for mechanical seals with installation length L_{1k} to EN 12756 (design KU):

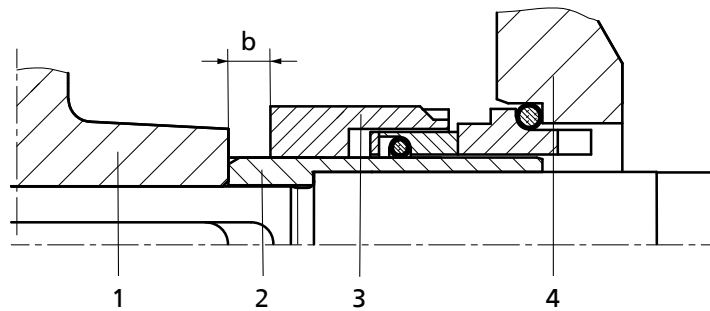
Fig. 19: Installation dimension b of mechanical seal

1	Impeller	2	Shaft sleeve
3	Mechanical seal	4	Casing cover

Table 24: Installation dimensions of the mechanical seal

Shaft unit ¹¹⁾	Installation dimension b
25	7,5 mm
35	10 mm
55	15 mm

7.5.3.2 Installing a double mechanical seal

See supplementary operating manual.

7.5.3.3 Fitting the gland packing

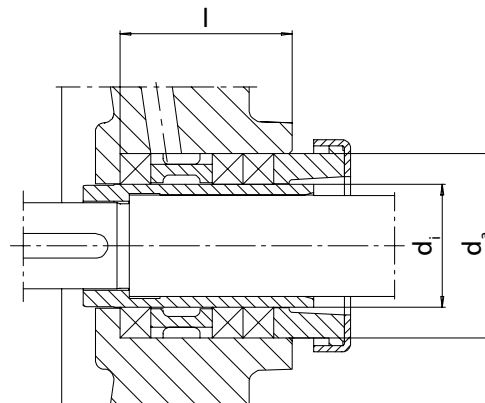

Fig. 20: Gland packing chamber

Table 25: Gland packing chamber

Shaft unit ¹²⁾	Gland packing chamber			Packing cross-section	Packing rings ¹³⁾
	$\varnothing d_i$	$\varnothing d_a$	l		
25	30	46	45	$\square 8 \times 126$	3 packing rings 1 lantern ring
35	40	60	56	$\square 10 \times 165$	3 packing rings 1 lantern ring
55	50	70	56	$\square 10 \times 196$	3 packing rings 1 lantern ring

✓ The notes and steps stated in (⇒ Section 7.5.1, Page 57) to (⇒ Section 7.5.2, Page 57) have been observed/carried out.

✓ The bearing assembly as well as the individual parts have been placed in a clean

11) Shaft unit see data sheet.

12) Shaft unit see data sheet.

13) For operation with positive suction head and suction pressure > 0.5 bar, the lantern ring is replaced by two additional packing rings.

and level assembly area.

- ✓ All dismantled parts have been cleaned and checked for wear.
- ✓ Any damaged or worn parts have been replaced by original spare parts.
- ✓ The sealing surfaces have been cleaned.



Fig. 21: Packing ring cut to size

Variant with packing ring cut to size

1. Clean the packing chamber.
2. Insert packing ring 461 into the packing chamber of casing cover 161.
3. Use stuffing box ring 454 to tamp down packing ring 461.
4. Slide the shaft protecting sleeve (chamfered side first) into the gland packing chamber from the pump end.
5. Insert lantern ring 458, if any (see drawing above).
Insert subsequent packing rings one at a time, with their joints staggered at approximately 90°. Use stuffing box ring 454 to seat each individual packing ring in the packing chamber. Once each packing ring is in place, slide shaft protecting sleeve 524 back into position.
6. Position gland follower 452 on studs 902.2. Fasten by tightening nuts 920.2 lightly and evenly.
Do not pack down packing rings 461 yet.
7. Use a feeler gauge to verify that gland follower 452 is fitted centred and at a right angle to the shaft.
8. Slide new gasket 400.75 onto shaft 210.
9. On models with a bolted casing cover undo forcing screws 901.31 without removing them.
10. Place casing cover 161 into the locating fit of bearing bracket 330. Verify that shaft 210 and shaft protecting sleeve 524 are aligned properly.
11. On models with a clamped casing cover, fasten cover plates 81-92.01 and 81-92.02 with transport locks 901.98 and lock washers 554.98. The casing cover is now fastened to the bearing bracket.
12. Fit and tighten nuts 920.15, if any.
13. Tighten gland follower 452 lightly and evenly.
The rotor must be easy to rotate.

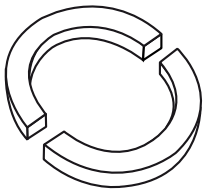

Fig. 22: Pure graphite packing ring

Variant with pure graphite packing ring

1. Clean the packing chamber.
2. Insert pure graphite packing ring 461.
3. Use stuffing box ring 454 to tamp down pure graphite packing ring 461.
4. Slide the shaft protecting sleeve (chamfered side first) into the gland packing chamber from the pump end.
A visible gap must remain between shaft protecting sleeve 524 and the packing rings.
5. Insert subsequent pure graphite packing rings 461 one at a time, with their joints staggered at approximately 90°. Use stuffing box ring 454 to seat each individual packing ring in the packing chamber. Once each packing ring is in place, slide shaft protecting sleeve 524 back into position.
The pure graphite packing rings 461 must always fit snugly in the stuffing box.
6. Position gland follower 452 on studs 902.2. Fasten by tightening nuts 920.2 lightly and evenly.
7. Use a feeler gauge to verify that gland follower 452 is fitted centred and at a right angle to the shaft.
8. Slide new gasket 400.75 onto shaft 210.
9. On models with a bolted casing cover undo forcing screws 901.31 without removing them.
10. Place casing cover 161 into the locating fit of bearing bracket 330. Verify that shaft 210 and shaft protecting sleeve 524 are aligned properly.

11. On models with a clamped casing cover, fasten cover plates 81-92.01 and 81-92.02 with transport locks 901.98 and lock washers 554.98. The casing cover is now fastened to the bearing bracket.
12. Fit and tighten nuts 920.15, if any.
13. Tighten gland follower 452 lightly and evenly.
The rotor must be easy to rotate.

7.5.4 Fitting the impeller

- ✓ The notes and steps stated in (⇒ Section 7.5.1, Page 57) to (⇒ Section 7.5.3, Page 59) have been observed/carried out.
 - ✓ The assembled bearing bracket as well as the individual parts are kept in a clean and level assembly area.
 - ✓ All dismantled parts have been cleaned and checked for wear.
 - ✓ Any damaged or worn parts have been replaced by original spare parts.
 - ✓ The sealing surfaces have been cleaned.
1. Insert key 940.09 and, if applicable, key 940.09. Slide impeller 230 onto shaft 210.
 2. Fasten impeller nut 920.95, lock washer 930.95 and disc 550.95, if any. (See table: Tightening torques of screwed connections at the pump).

7.5.5 Installing the back pull-out unit

	<p>! WARNING</p>
	<p>Back pull-out unit tilting Risk of crushing hands and feet!</p> <ul style="list-style-type: none"> ▷ Suspend or support the bearing bracket at the pump end.

- ✓ The notes and steps stated in (⇒ Section 7.5.1, Page 57) to (⇒ Section 7.5.4, Page 62) have been observed/carried out.
 - ✓ Any damaged or worn parts have been replaced by original spare parts.
 - ✓ The sealing surfaces have been cleaned.
 - ✓ For back pull-out units without coupling, fit the coupling in accordance with the manufacturer's instructions.
1. Insert new gasket 400.10 into volute casing 102.
 2. Loosen but do not remove forcing screws 901.30 or 901.31.
 3. If required, prevent the back pull-out unit from tipping over, e.g. by suspending or supporting it. Then insert it into volute casing 102.
 4. Tighten nut 920.01 at the volute casing. Observe the tightening torques.
 5. Bolt support foot 183 to the baseplate.

7.5.6 Mounting the motor

	<p>NOTE</p>
	<p>Steps 1 and 2 do not apply to versions with spacer-type coupling.</p>

1. Shift the motor to connect it to the pump via the coupling.
2. Fasten the motor to the baseplate.
3. Align pump and motor. (⇒ Section 5.7, Page 32)
4. Connect the motor to the power supply (refer to manufacturer's product literature).

7.6 Tightening torques

7.6.1 Tightening torque pump

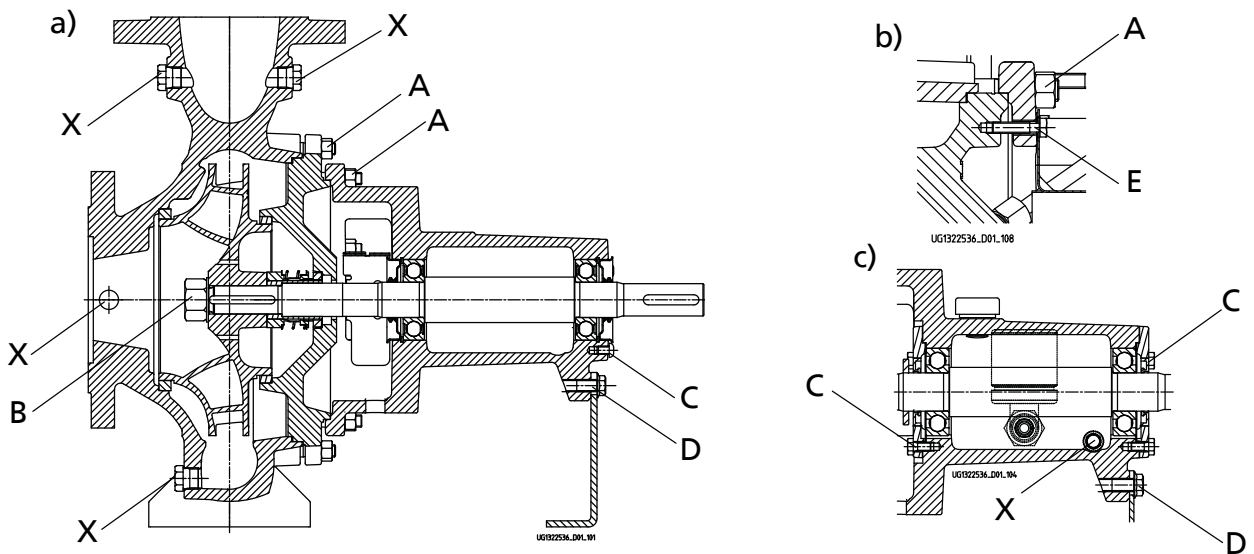

Fig. 23: Tightening points: model with bolted casing cover and grease lubrication (a), model with clamped casing cover (b) and oil lubrication (c)

Table 26: Tightening torques

Position	Thread	Tightening torques
		[Nm]
A	M12	55
	M16	130
B	M12 × 1,5	55
	M24 × 1,5	130
	M30 × 1,5	170
C	M8	20
	M10	38
D	M12	90
E	M6	5
X	1/8	25
	1/4	55
	3/8	80
	1/2	130
	3/4	220

7.6.2 Tightening torques for the pump set

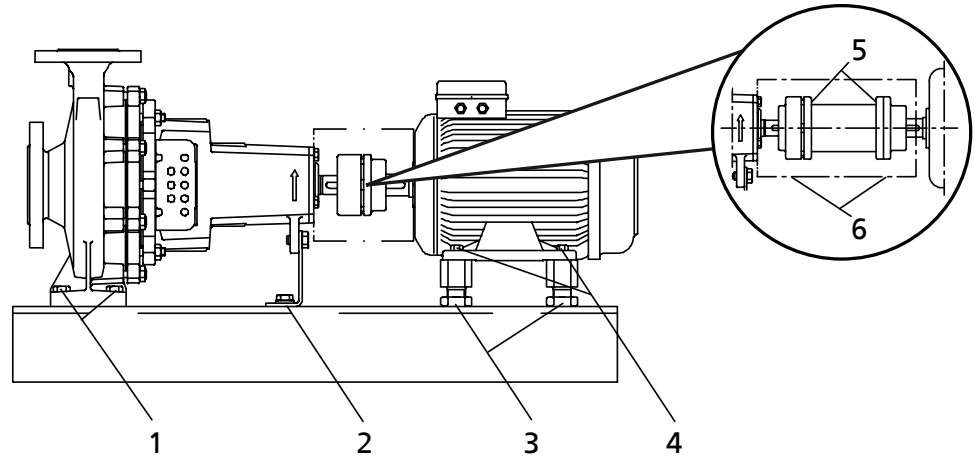

Fig. 24: Position of bolts/screws at the pump set

Table 27: Tightening torques for bolted/screwed connections at the pump set

Position	Thread size	Tightening torque	Comments
		[Nm]	
1	M12	30	Pump on baseplate
	M16	75	
	M20	75	
2	M12	30	
3	M24 × 1,5	140	Adjusting screws in baseplate
	M36 × 1,5	140	
4	M6	10	Motor on baseplate or motor on adjusting screws or bases
	M8	10	
	M10	15	
	M12	30	
	M16	75	
	M20	140	
	M24	140	
5	M6	13	Coupling (only for spacer-type coupling made by Flender)
	M8	18	
	M10	44	
6	M6	10	Coupling guard

7.7 Spare parts stock

7.7.1 Ordering spare parts

Always quote the following data when ordering replacement or spare parts:

- Order number
- Order item number
- Consecutive number
- Type series
- Size
- Material variant
- Seal code
- Year of construction

Refer to the name plate for all data. (⇒ Section 4.4, Page 19)

Also specify the following data:

- Part number and description (⇒ Section 9.1, Page 68)
- Quantity of spare parts
- Shipping address
- Mode of dispatch (freight, mail, express freight, air freight)



7.7.2 Recommended spare parts stock for 2 years' operation to DIN 24296

Table 28: Quantity of spare parts for recommended spare parts stock

Part No.	Description	Number of pumps (including stand-by pumps)						
		2	3	4	5	6 and 7	8 and 9	10 and more
210	Shaft	1	1	1	2	2	2	20 %
230	Impeller	1	1	1	2	2	2	20 %
321	Radial ball bearings (set)	1	1	2	2	2	3	25 %
330	Bearing bracket	-	-	-	-	-	1	2
502.1	Casing wear ring	2	2	2	3	3	4	50 %
502.2	Casing wear ring	2	2	2	3	3	4	50 %
-	Gaskets (set)	4	6	8	8	9	10	100 %
For variants with mechanical seal								
433	Mechanical seal	1	1	2	2	2	3	25 %
523	Shaft sleeve	2	2	2	3	3	4	50 %
For variants with gland packing¹⁴⁾								
461	Gland packing (set)	4	4	6	6	6	8	100 %
524	Shaft protecting sleeve	2	2	2	3	3	4	50 %

14) Parts 433, 523 are not used.

8 Trouble-shooting

	 WARNING
	<p>Improper work to remedy faults Risk of injury!</p> <p>▷ For any work performed to remedy faults, observe the relevant information given in this operating manual and/or in the product literature provided by the accessories manufacturer.</p>

If problems occur that are not described in the following table, consultation with the KSB customer service is required.

- A Pump delivers insufficient flow rate
- B Motor is overloaded
- C Excessive discharge pressure
- D Increased bearing temperature
- E Leakage at the pump
- F Excessive leakage at the shaft seal
- G Vibrations during pump operation
- H Impermissible temperature increase in the pump

Table 29: Trouble-shooting

A	B	C	D	E	F	G	H	Possible cause	Remedy ¹⁵⁾
X	-	-	-	-	-	-	-	Pump delivers against an excessively high pressure.	Re-adjust to duty point. Check system for impurities. Fit a larger impeller. ¹⁶⁾ Increase the speed (turbine, I.C. engine).
X	-	-	-	-	-	X	X	Pump or piping are not completely vented or primed.	Vent and/or prime.
X	-	-	-	-	-	-	-	Supply line or impeller clogged	Remove deposits in the pump and/or piping.
X	-	-	-	-	-	-	-	Formation of air pockets in the piping	Alter piping layout. Fit vent valve.
X	-	-	-	-	-	X	X	Suction lift is too high/NPSHavailable (positive suction head) is too low.	Check/alter fluid level. Install pump at a lower level. Fully open the shut-off element in the suction line. Change suction line, if the friction losses in the suction line are too high. Check any strainers installed/suction opening. Observe permissible speed of pressure fall.
X	-	-	-	-	-	-	-	Air intake at the shaft seal	Supply external barrier fluid, if necessary, or increase barrier fluid pressure. Replace shaft seal.
X	-	-	-	-	-	-	-	Wrong direction of rotation	Check the electrical connection of the motor and the control system, if any.
X	-	-	-	-	-	-	-	Speed is too low. - Operation with frequency inverter - Operation without frequency inverter	- Increase voltage/frequency at the frequency inverter in the permissible range. - Check voltage.
X	-	-	-	-	-	X	-	Wear of internal components	Replace worn components by new ones.
-	X	-	-	-	-	X	-	Pump back pressure is lower than specified in the purchase order.	Re-adjust to duty point. In the case of persistent overloading, turn down impeller. ¹⁶⁾

15) Pump pressure must be released before attempting to remedy faults on parts which are subjected to pressure.

16) Contact the manufacturer.

A	B	C	D	E	F	G	H	Possible cause	Remedy ¹⁵⁾
-	X	-	-	-	-	-	-	Density or viscosity of fluid handled higher than stated in purchase order	Contact the manufacturer.
-	-	-	-	-	X	-	-	Use of unsuitable shaft seal materials	Change the material combination. ¹⁶⁾
-	X	-	-	-	X	-	-	Gland follower over-tightened or cocked	Adjust.
-	X	X	-	-	-	-	-	Speed is too high.	Reduce speed. ¹⁶⁾
-	-	-	-	X	-	-	-	Tie bolts/sealing element defective	Fit new sealing element between volute casing and casing cover. Re-tighten the bolts.
-	-	-	-	-	X	-	-	Worn shaft seal	Fit new shaft seal. Check flushing liquid/barrier fluid.
X	-	-	-	-	X	-	-	Score marks or roughness on shaft protecting sleeve / shaft sleeve	Replace shaft protecting sleeve/shaft sleeve. Fit new shaft seal.
-	-	-	-	-	X	-	-	Dismantle to find out.	Correct. Fit new shaft seal, if required.
-	-	-	-	-	X	-	-	Vibrations during pump operation	Correct the suction conditions. Re-align the pump set. Re-balance the impeller. Increase pressure at the pump suction nozzle.
-	-	-	X	-	X	X	-	Pump set is misaligned.	Re-align pump set.
-	-	-	X	-	X	X	-	Pump is warped or sympathetic vibrations in the piping.	Check the piping connections and secure fixing of pump; if required, reduce distances between the pipe clamps. Fix the pipelines using anti-vibration material.
-	-	-	X	-	-	-	-	Increased axial thrust ¹⁶⁾	Clean balancing holes in the impeller. Replace the casing wear rings.
-	-	-	X	-	-	-	-	Insufficient or excessive quantity of lubricant or unsuitable lubricant.	Top up, reduce or change lubricant.
-	-	-	X	-	-	-	-	Non-compliance with specified coupling distance	Correct the distance according to general arrangement drawing.
X	X	-	-	-	-	-	-	Motor is running on two phases only.	Replace the defective fuse. Check the electric cable connections.
-	-	-	-	-	-	X	-	Rotor out of balance	Clean the impeller. Re-balance the impeller.
-	-	-	-	-	-	X	-	Defective bearing(s)	Replace.
-	-	-	X	-	-	X	X	Flow rate is too low.	Increase the minimum flow rate.
-	-	-	-	-	X	-	-	Incorrect inflow of circulation liquid	Increase the free cross-section.

Part No.	Description	Part No.	Description
400.10/75	Gasket	920.01/15/95	Hexagon nut
411.01/02/03/04	Joint ring	930.95	Spring washer
411.77/78	Axial seal ring	932.01/02	Circlip
433	Mechanical seal	940.01/02/09 ¹⁸⁾	Key
502.01/02	Casing wear ring ¹⁹⁾		
Connections:			
1M	Connection for pressure gauge	6D	Fluid priming and venting
6B	Fluid drain	8B	Leakage drain

18) For shaft units 55 and 60 only
 19) Optional for casing material C

9.1.2 Standardised mechanical seal and clamped casing cover

This view applies to the following pump sizes:

- | | | | | | | | | |
|-------------|--------------|-------------|-------------|-------------|-------------|-------------|-------------|-------------|
| 040-025-160 | 050-32-125.1 | 065-040-125 | 065-050-125 | 080-065-125 | 100-080-160 | 125-100-160 | 150-125-200 | 200-150-200 |
| | 050-32-160.1 | 065-040-160 | 065-050-160 | 080-065-160 | 100-080-200 | 125-100-200 | | |
| | 050-32-125 | | | | | | | |
| | 050-32-160 | | | | | | | |

[Supplied in packaging units only

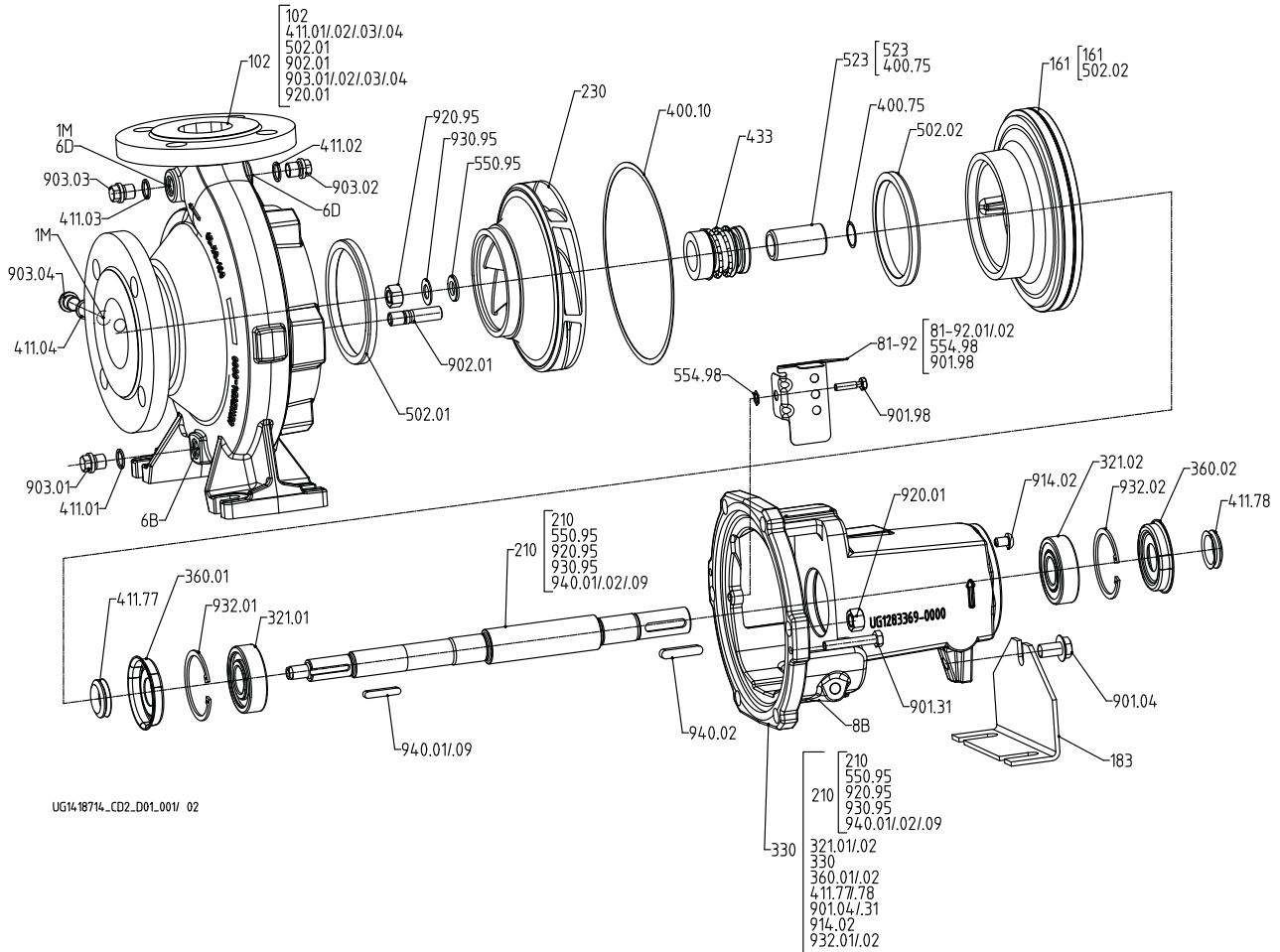

Fig. 26: Pump set with standardised mechanical seal and clamped casing cover

Table 31: List of components

Part No.	Description	Part No.	Description
102	Volute casing	523	Shaft sleeve
161	Casing cover	550.95 ²⁰⁾	Disc
183	Support foot	554.98	Lock washer
210	Shaft	81-92.01/02	Cover plate
230	Impeller	901.04/30/31/98	Hexagon head bolt
321.01/02	Deep groove ball bearing	902.01/15	Stud
330	Bearing bracket	903.01/02/03/04	Screw plug
360.01/02	Bearing cover	914.02	Round-head screw
400.10/75	Gasket	920.01/95	Hexagon nut
411.01/02/03/04	Joint ring	930.95	Spring washer
411.77/78	Axial seal ring	932.01/02	Circlip

²⁰⁾ For shaft unit 25 only

Part No.	Description	Part No.	Description
433	Mechanical seal	940.01/02/09 ²¹⁾	Key
502.01/02 ²²⁾	Casing wear ring ²³⁾		
Connections:			
1M	Connection for pressure gauge	6D	Fluid priming and venting
6B	Fluid drain	8B	Leakage drain

21) For shaft units 55 and 60 only

22) Not on sizes 040-025-160, 050-32-125.1, 050-32-160.1, 050-32-125, 050-32-160, 065-040-125

23) Optional for casing material C

Part No.	Description	Part No.	Description
452	Gland follower	930.95	Spring washer
454	Stuffing box ring	932.01/.02	Circlip
458	Lantern ring	940.01/.02/.09 ²⁶⁾	Key
Connections:			
1M	Connection for pressure gauge	6D	Fluid priming and venting
6B	Fluid drain	8B	Leakage drain

26) For shaft units 55 and 60 only

9.1.4 Gland packing and clamped casing cover

This view applies to the following pump sizes:

- | | | | | | | | | |
|-------------|--------------|-------------|-------------|-------------|-------------|-------------|-------------|-------------|
| 040-025-160 | 050-32-125.1 | 065-040-125 | 065-050-125 | 080-065-125 | 100-080-160 | 125-100-160 | 150-125-200 | 200-150-200 |
| | 050-32-160.1 | 065-040-160 | 065-050-160 | 080-065-160 | 100-080-200 | 125-100-200 | | |
| | 050-32-125 | | | | | | | |
| | 050-32-160 | | | | | | | |

[Supplied in packaging units only

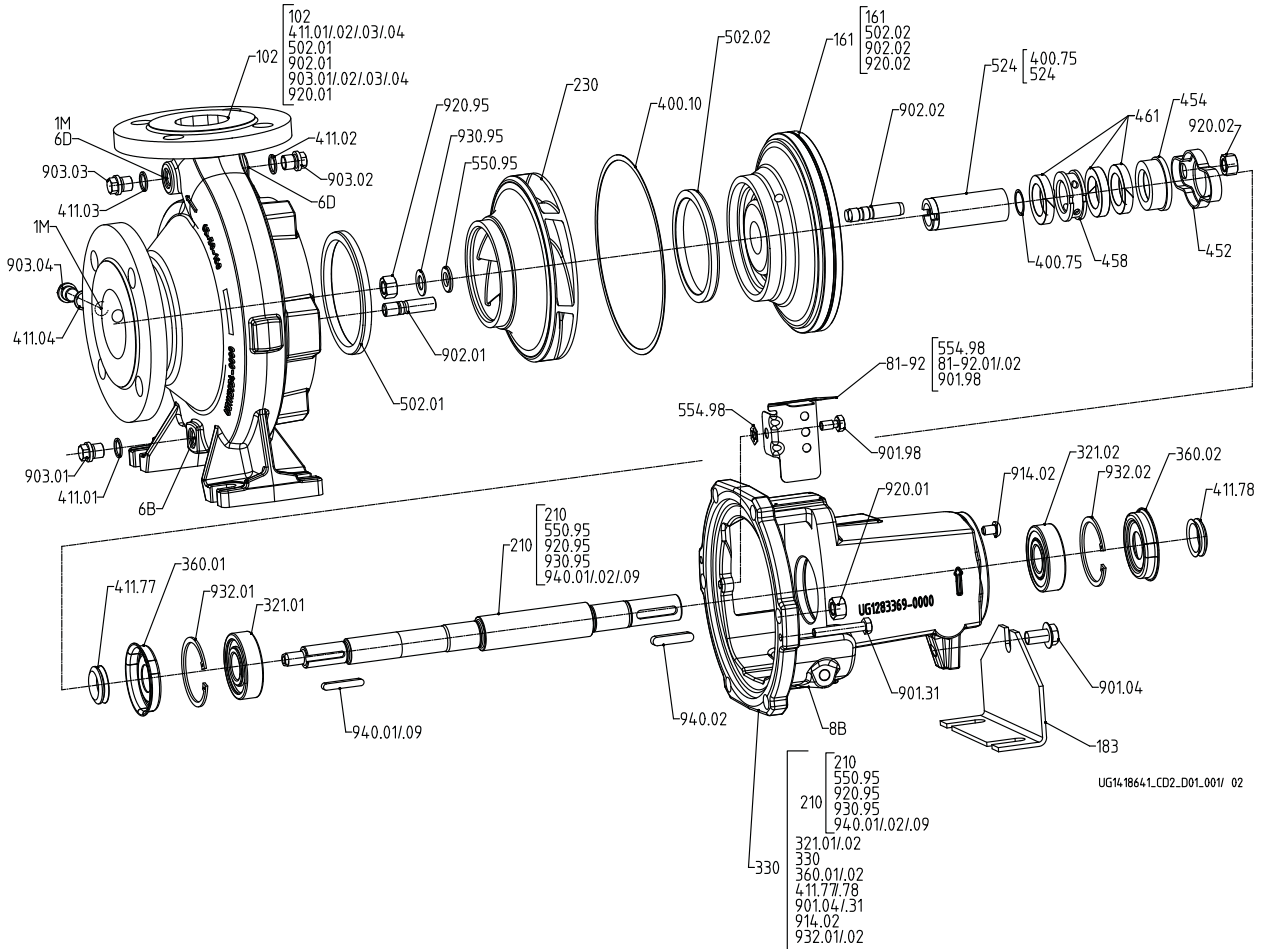

Fig. 28: Pump set with gland packing and clamped casing cover

Table 33: List of components

Part No.	Description	Part No.	Description
102	Volute casing	461	Gland packing
161	Casing cover	502.01/02 ²⁷⁾	Casing wear ring ²⁸⁾
183	Support foot	524	Shaft protecting sleeve
210	Shaft	550.95 ²⁹⁾	Disc
230	Impeller	554.98	Lock washer
321.01/02	Deep groove ball bearing	81-92.01/02	Cover plate
330	Bearing bracket	901.04/30/98	Hexagon head bolt
360.01/02	Bearing cover	902.01/02	Stud
400.10/75	Gasket	903.01/02/03/04	Screw plug
411.01/02/03/04	Joint ring	914.02	Round-head screw
411.77/78	Axial seal ring	920.01/02/15/95	Hexagon nut

27) Not on sizes 040-025-160, 050-32-125.1, 050-32-160.1, 050-32-125, 050-32-160, 065-040-125
 28) Optional for casing material C
 29) For shaft unit 25 only

Part No.	Description	Part No.	Description
452	Gland follower	930.95	Spring washer
454	Stuffing box ring	932.01/02	Circlip
458	Lantern ring	940.01/02/09 ³⁰⁾	Key
Connections:			
1M	Connection for pressure gauge	6D	Fluid priming and venting
6B	Fluid drain	8B	Leakage drain

9.1.5 Reinforced bearings

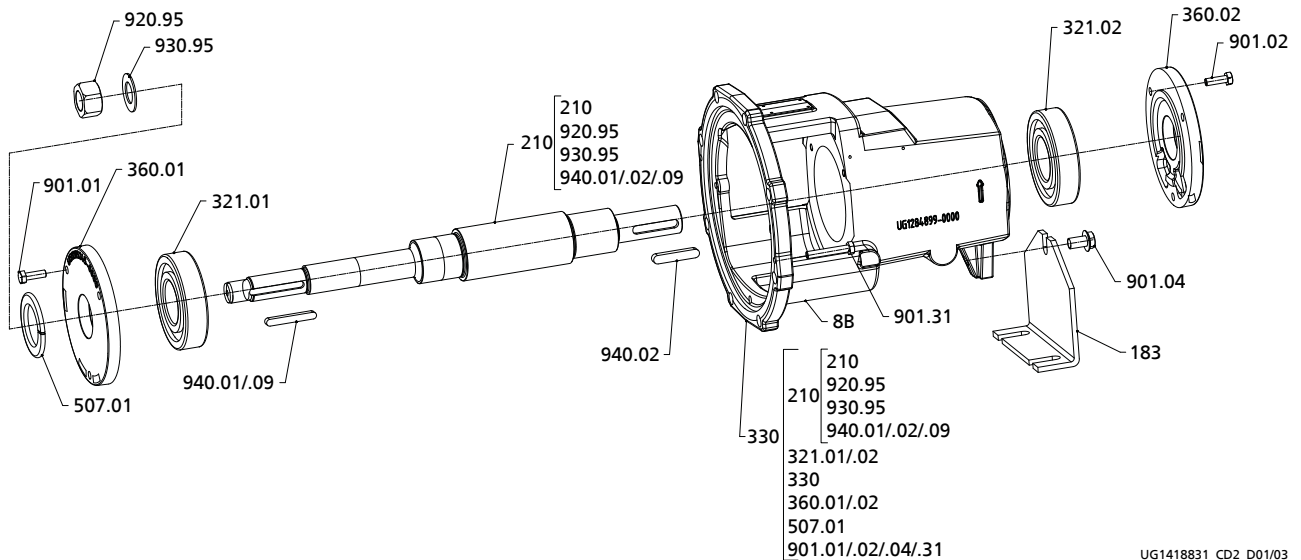

UG1418831_CD2_D01/03

Fig. 29: Version with reinforced bearings (shaft units 50 and 60)

Table 34: List of components³¹⁾

Part No.	Description	Part No.	Description
183	Support foot	507.01	Thrower
210	Shaft	901.01/02/04/31	Hexagon head bolt
330	Bearing bracket	920.95	Hexagon nut
321.01/02	Deep groove ball bearing	930.95	Spring washer
360.01/02	Bearing cover	940.01/02/09 ³²⁾	Key
Connections:			
8B	Leakage drain		

30) For shaft units 55 and 60 only

31) Some individual components might not be applicable, depending on the size and shaft material.

32) For shaft unit 60 only

9.1.6 Oil lubrication with constant level oiler

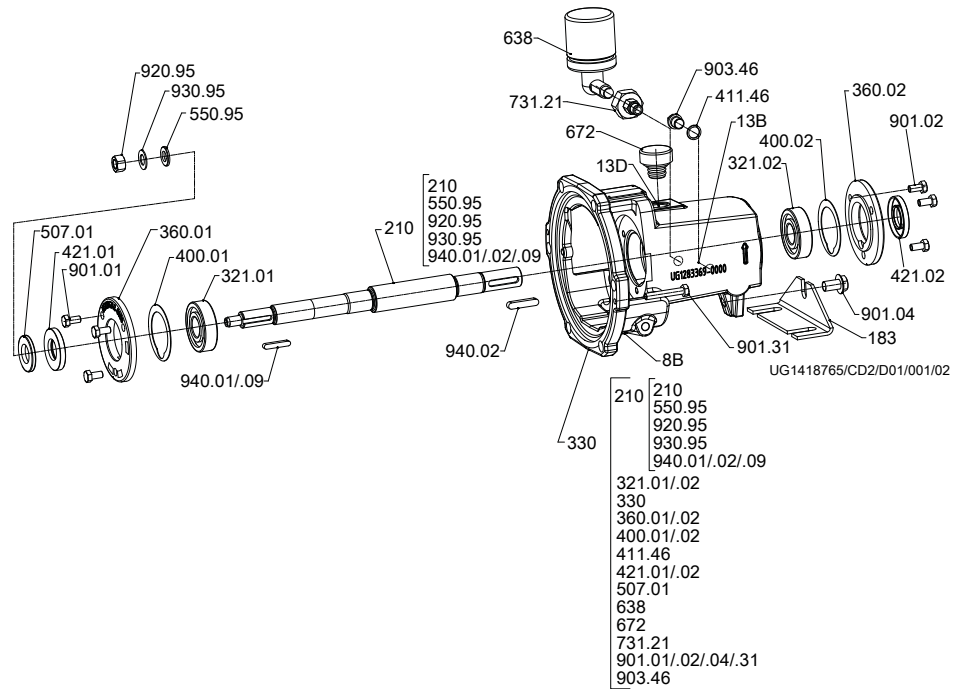

Fig. 30: Version with oil lubrication and constant level oiler

Table 35: List of components³³⁾

Part No.	Description	Part No.	Description
183	Support foot	638	Constant level oiler
210	Shaft	642 ³⁴⁾	Oil level sight glass
330	Bearing bracket	672	Vent
321.01/.02	Deep groove ball bearing	731.21	Pipe union
360.01/.02	Bearing cover	901.01/.02/.04/.31	Hexagon head bolt
400.01/.02	Gasket	903.46	Screw plug
411.46	Joint ring	920.95	Hexagon nut
421.01/.02	Lip seal	930.95	Spring washer
507.01	Thrower	940.01/.02/.09 ³⁵⁾	Key
550.95 ³⁶⁾	Disc		
Connections:			
8B	Leakage drain	13D	Oil filling and venting
13B	Oil drain		

33) Some individual components might not be applicable, depending on the size and material.

34) Always supplied with constant level oiler and oil level sight glass for region B.

35) For shaft units 55 and 60 only

36) For shaft unit 25 only

10 EU Declaration of Conformity

Manufacturer: **KSB SE & Co. KGaA**
Johann-Klein-Straße 9
67227 Frankenthal (Germany)

The manufacturer herewith declares that the product:

Etabloc, Etabloc SYT, Etaline, Etaline SYT, Etaline Z, Etachrom B, Etachrom L, Etanorm, Etanorm SYT, Etanorm V, Etaprime L, Etaprime B, Vitachrom

KSB order number:

- is in conformity with the provisions of the following Directives as amended from time to time:
 - Pump (set): Machinery Directive 2006/42/EC

The manufacturer also declares that

- the following harmonised international standards have been applied:
 - ISO 12100
 - EN 809

Person authorised to compile the technical file:

Name
Function
Address (company)
Address (Street, No.)
Address (post or ZIP code, city) (country)

The EU Declaration of Conformity was issued in/on:

Place, date

.....³⁷⁾.....

Name
Function
Company
Address

37) A signed, legally binding EU Declaration of Conformity is supplied with the product.

Index

A

Auxiliary connections 30

B

Bearing temperature 48

Bearings 20

C

Certificate of decontamination 78

Clearances 49

Commissioning 37

Configuration 21

Constant level oiler 37

Coupling 49

Coupling alignment 32

D

Design 19

Direction of rotation 36

Dismantling 54

Disposal 15

E

Event of damage 7

Ordering spare parts 64

Exploded view 68, 70, 72, 74

Explosion protection 11, 23, 31, 33, 34, 35, 36, 38, 40, 42, 43, 46, 47, 48, 49, 50

F

Faults

Causes and remedies 66

Fields of application 9

Filter 26, 49

Final check 39

Fluid handled

Density 44

Frequency of starts 43

Function 21

G

General assembly drawing 68, 70, 72, 74, 75, 76

Gland packing 41

Grease lubrication

Grease quality 52

Intervals 52

I

Impeller type 20

Installation

Installation on a foundation 24
without foundation 25

Installation at site 23

Intended use 9

K

Key to safety symbols/markings 8

L

Leakage rate 41

Lubrication 21

M

Maintenance 47

Mechanical seal 41

Monitoring equipment 12

N

Name plate 19

Noise characteristics 22

O

Oil lubrication

Intervals 50

Oil quality 50

Oil quantity 51

Operating limits 42

Order number 7

Other applicable documents 7

P

Partly completed machinery 7

Permissible forces at the pump nozzles 27

Piping 26

Preservation 14, 45

Priming and venting 39

Product code 16

Product description 16

Pump casing 20

Pure graphite packing 41

R

Reassembly 54, 57

Return to supplier 14

Returning to service 45

Running noises 47

S

Safety 9
Safety awareness 10
Scope of supply 22
Shaft seal 20
Shutdown 45
Spare part
 Ordering spare parts 64
Spare parts stock 65
Start-up 40
Storage 14, 45

T

Temperature limits 11
Tightening torques 63, 64
Transport 13

W

Warnings 8
Warranty claims 7

KSb. IRAN

www.ksbiran.com

KSb. IRAN

www.ksbiran.com

KSb. IRAN

www.ksbiran.com

Ksb. IRAN

www.ksbiran.com

